

# **CR-TEC Engineering**

**A u t o m a t e d V a l v e S o l u t i o n s**

## **Installation, Operation, & Maintenance Instructions**

### **CR50S & CR50S Modulating** Compact Electric Actuator

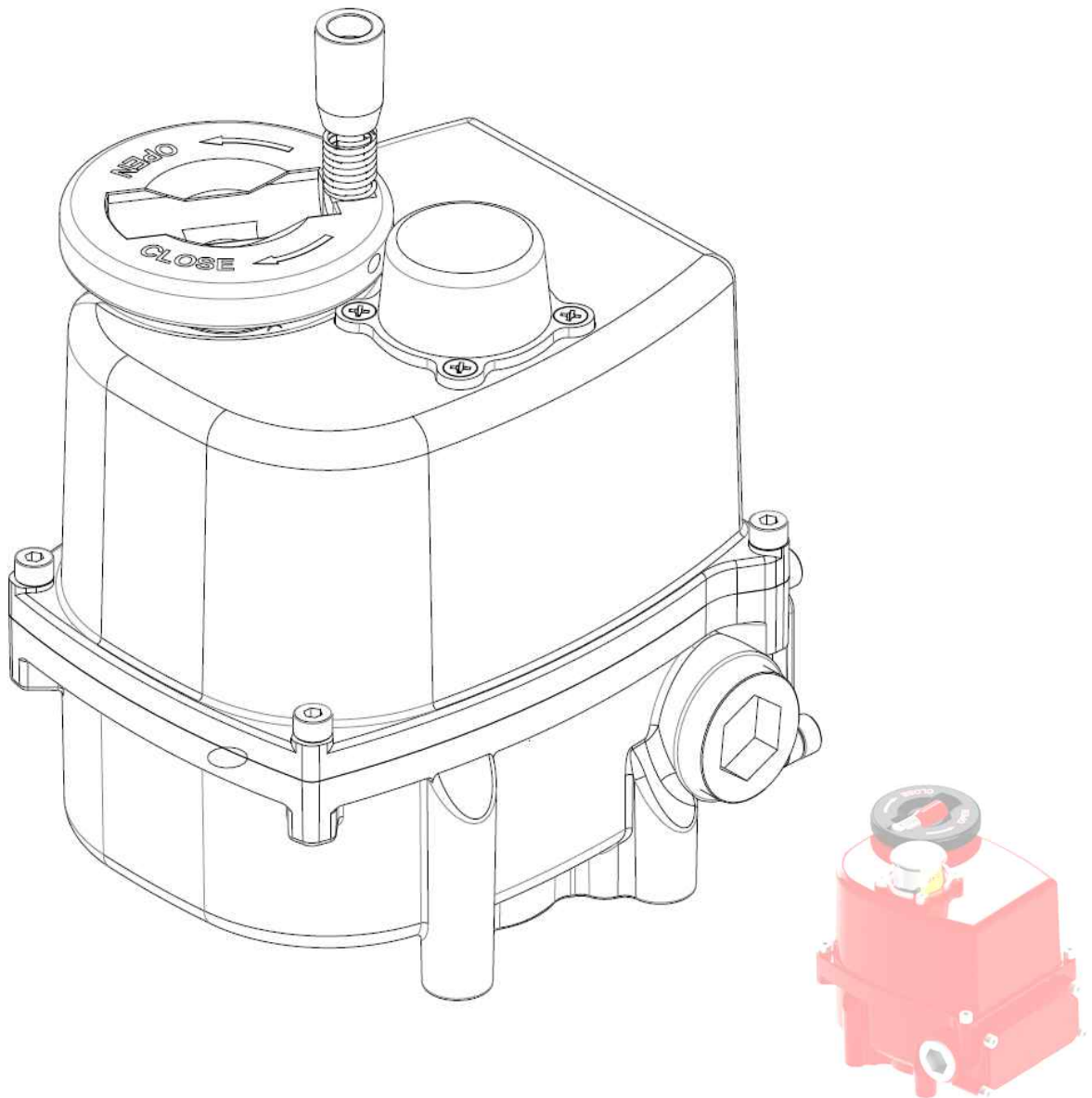

## Table of Contents

### **1.Pre-Installation Inspection**

### **2.Storage**

### **3.Structure of Actuator**

### **4.Specifications**

### **5.Dimensions**

### **6.Actuator Installation and Set-up**

- A. Valve mounting
- B. Wiring
- C. Limit switch setting
- D. Manual operation

### **7.Troubleshooting**

### **8.Maintenance**

- A. Lubrication
- B. Regular Operation
- C. Maintenance

### **9.Instruction of PCU Card**

- A. Layout of PCU
- B. Specifications of PCU
- C. Mode Setting
- D. Modulating Set-up

## 1. Pre-Installation Inspection

- A. Actuator should be selected with 30% safety factor of the maximum torque of the valve when selecting the actuators.
- B. Check for correct voltage prior to wiring.
- C. Turn power off before servicing or for maintenance purpose.
- D. Use sealant to seal conduit connections after wiring to prevent dusting or water contamination.
- E. The angle of electric actuator installation must be between 0~180 degree.  
Do not install upside down or below the horizontal.
- F. When more than one electric actuator needed to operate simultaneously, please connect with the individual cables.
- G. When connecting the power supply, 1mm<sup>2</sup>, 18AWG or more cable should be used and it shall be connected through over-current protection device(circuit breaker) at 125% or more of the rated current.
- H. Please connect the ground wire.
  - I. Not intended for vacuum spaces and avoid installing (near)explosive atmospheres.
  - J. To avoid functional failure caused by statics, do not touch any components on the PCB with metal tools or etc.

**Warning :** Use caution when working in, with, or around valves and actuators.  
High pressures, forces, voltages and flammable media can be present.

**Warning :** Failure to follow instructions for proper electrical wiring, storage, set-up and maintenance may cause serious injury, damage equipment, or void warranty.

## 2. Storage

If you actuator cannot be installed immediately store it in a dry place, it must be protected from excess moisture, dust and weather until you are ready to connect incoming cables.

If the actuator has to be installed but cannot be cable, please don't remove the plastic cable entry plugs. When the actuator has to be cable, it is recommended that to replace with suitable water-proof plugs and have IP67 protection

### 3. Structure of Actuator

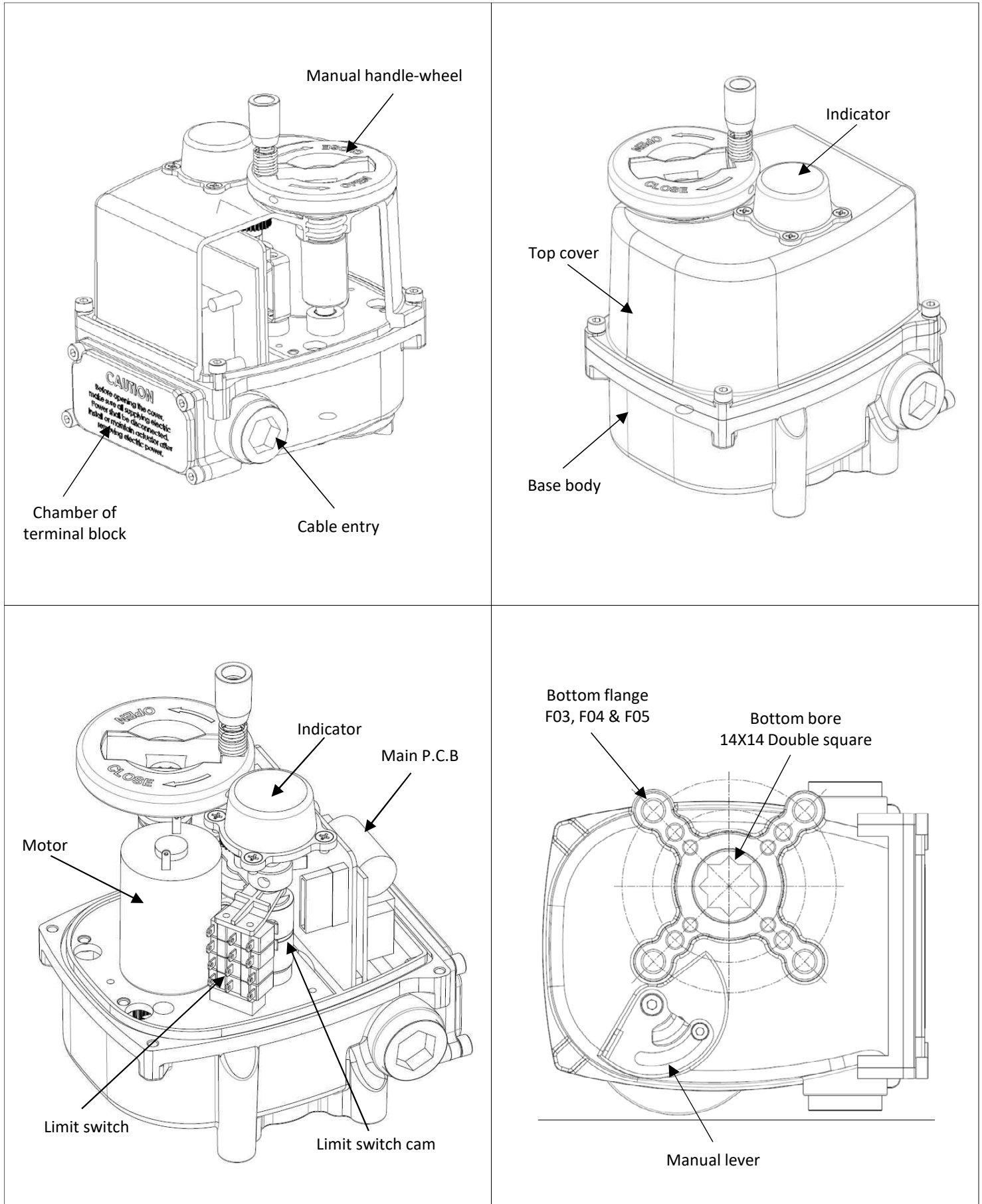

#### 4. Specification

Supplying power $\pm 10\%$	95 to 245 VAC 50/60Hz (1Ph), 24 VAC 50/60Hz, & 24 VDC
Power Consumption - Operation	20 Watt Max
Power Consumption - Idle	1.5 Watt Max
Motor	S2 30 Min. (Modulating: S4 50% 1200 Start/hour)
Limit switch	2 X Open/Close SPDT (250VAC 3A , 125VAC 5A)
Auxiliary limit switch	2 X Open/Close SPDT (250VAC 3A , 125VAC 5A)
Wire Size	12 to 18 AWG (Use Solid Wires)
Manual override	Handle-wheel with manual lever (17 Turns)
Space heater	1W
Ambient temperature	-4° F to 140° F (-20° C to +60°C)
Ambient humidity	90% Rh Max. (non-condensing)
Cable entry	2 X PF ½"
Materials	Aluminum Die-Casting
Bottom Flange(ISO5211 )	F03, F05 & F07
Bottom Bore	14 X 14 Double square (11X11mm available)
Operation Time (No Load)	13sec.
Indicator	Dome type mechanical indicator
Travel Angle $\pm 5\%$	90°
Enclosure	Weather-proof IP67

## 5. Dimension

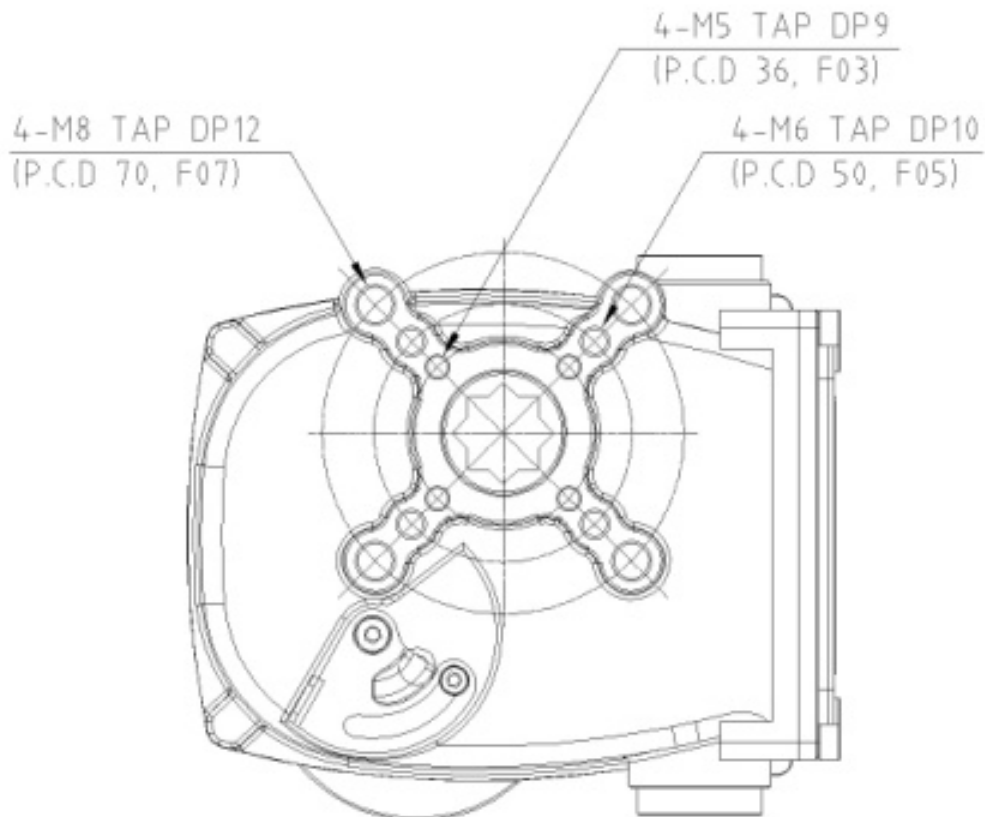
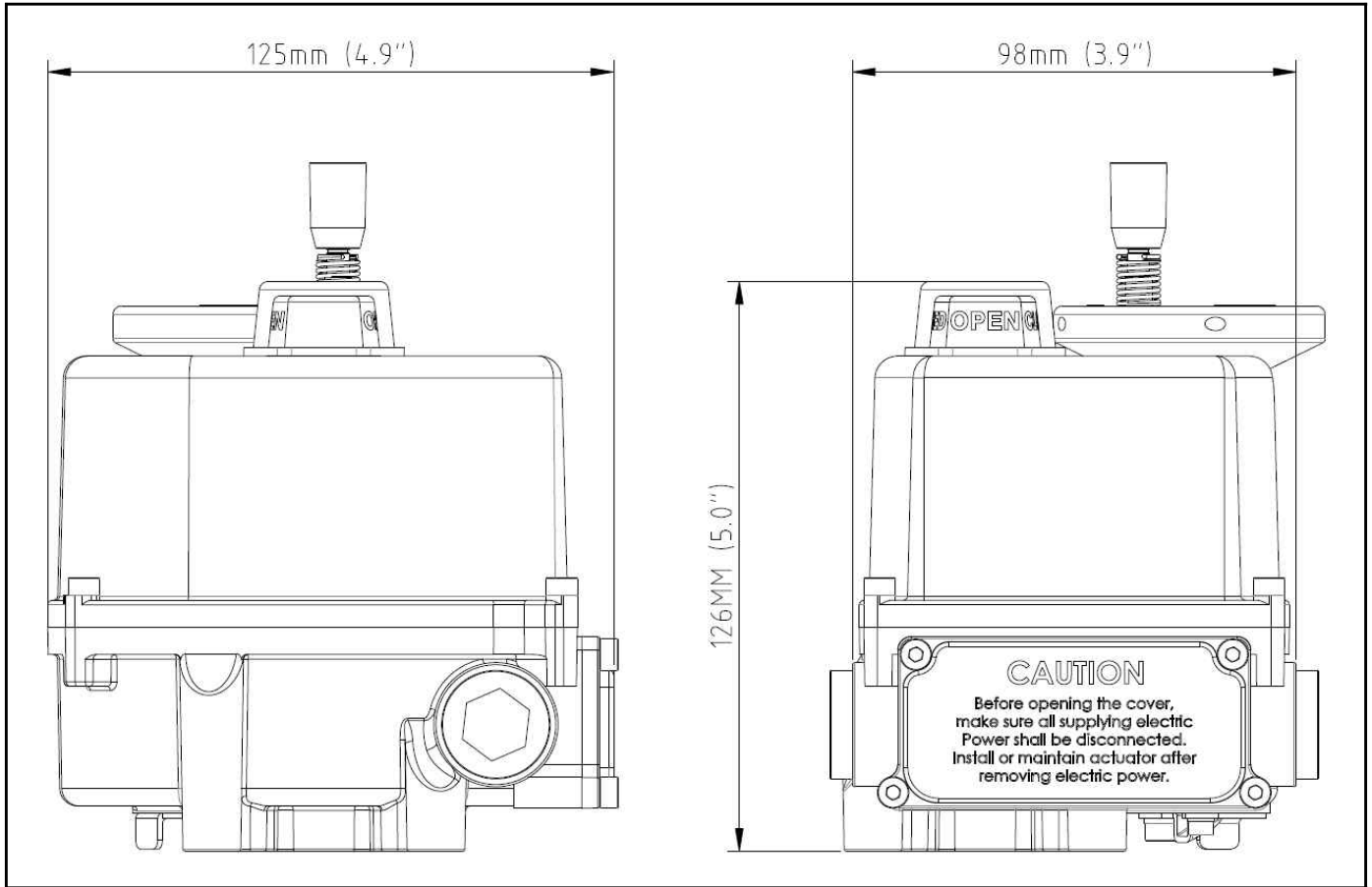

## 6. Actuator Installation and Set-up

### A. Valve mounting

Mounting is most easily done with the valve shaft pointing vertically upward, but the actuator may be mounted in any position.

CR50S actuators are supplied with a female drive output.

The bottom bolt pattern is drilled as F03, F05 & F07 according to ISO5211.

It is mandatory that the actuator be firmly secured to a sturdy mounting bracket or directly mounted to the valves ISO mounting pad. High tensile bolts or studs with spring locking washers must be used.

The valve output stem must be in line with the actuator output drive to avoid side loading of the stem.

To prevent backlash, no flexibility in the mounting bracket arrangement should be present.

### B. Wiring

#### a. Precaution

- (1) Cable entries are machined with PF 1/2 and sealed by plug before delivery.
- (2) Please remain the plug as it is if user doesn't use both cable entries.
- (3) Please make sure to seal the entries by using rubber or metallic packing after wiring, so that water or other foreign material may not come in.
- (4) If suitable cable connection is not used for wiring, factory won't guaranty the performance.

#### b. Electrical wiring

- (1) Check if the electrical specification like as power, wiring or etc are correct.
- (2) Wiring diagram is to be supplied together with the actuator.
- (3) Do the wiring as per the given wiring diagram, such as power, control power, internal wiring and ground.
- (4) Make sure to supply the electric power to the heater to keep inside of the actuator clean and dry for anti-condensation.
- (5) Make sure to check if wiring to the terminal is connected firmly.
- (6) Make sure that one relay operates one actuator only (Can't operate two or more actuators).
- (7) Make sure to clean inside of the actuator and no foreign material inside.
- (8) After the testing, check that all cable glands are correctly tightened.

Applicable cable glands should be selected to meet the application's condition.

It is recommended to use the grade of IP67 cable gland.

***Make sure all incoming power is disconnected before wiring!!!***

#### c. How to connect

"Pluggable connection system" terminal block is installed for saving time of wiring job and it is make the wiring job easy or simple

- (1) Remove cable plug and open cover of chamber of terminal block
- (2) Disassemble female connector from terminal block
- (3) Insert wires through cable entry.
- (4) Connect wires to female connector according to wiring diagram
- (5) Plug female connector in male header

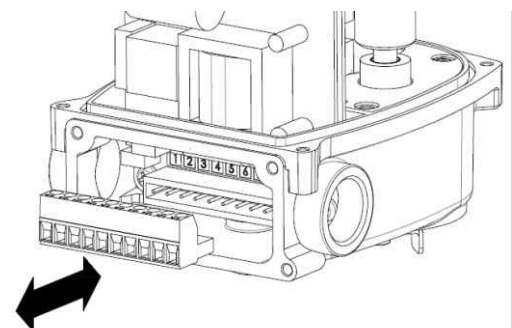

d. Wiring Diagram

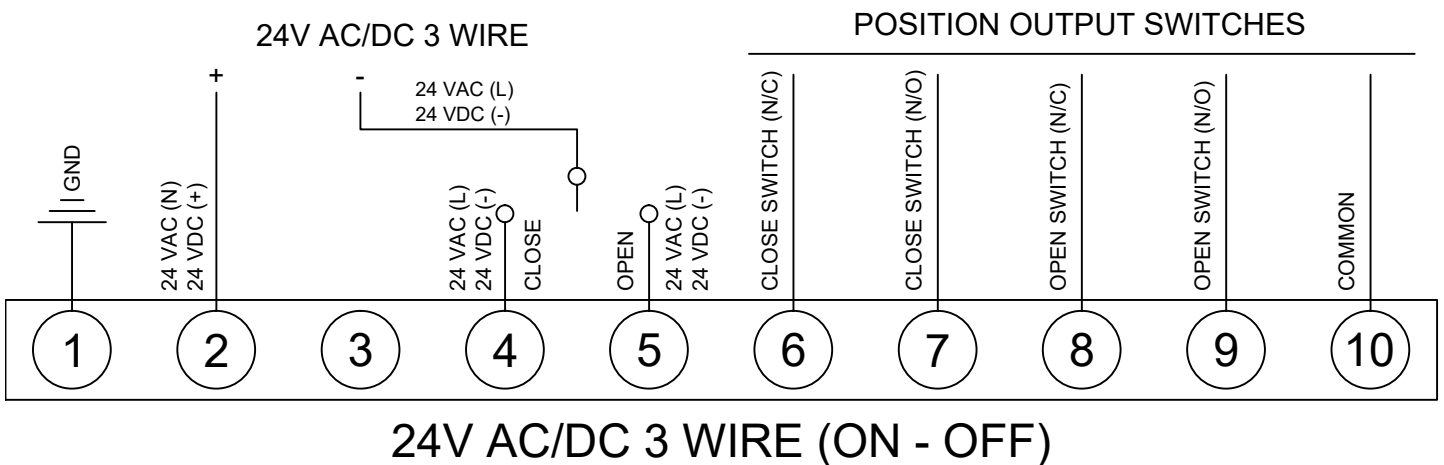
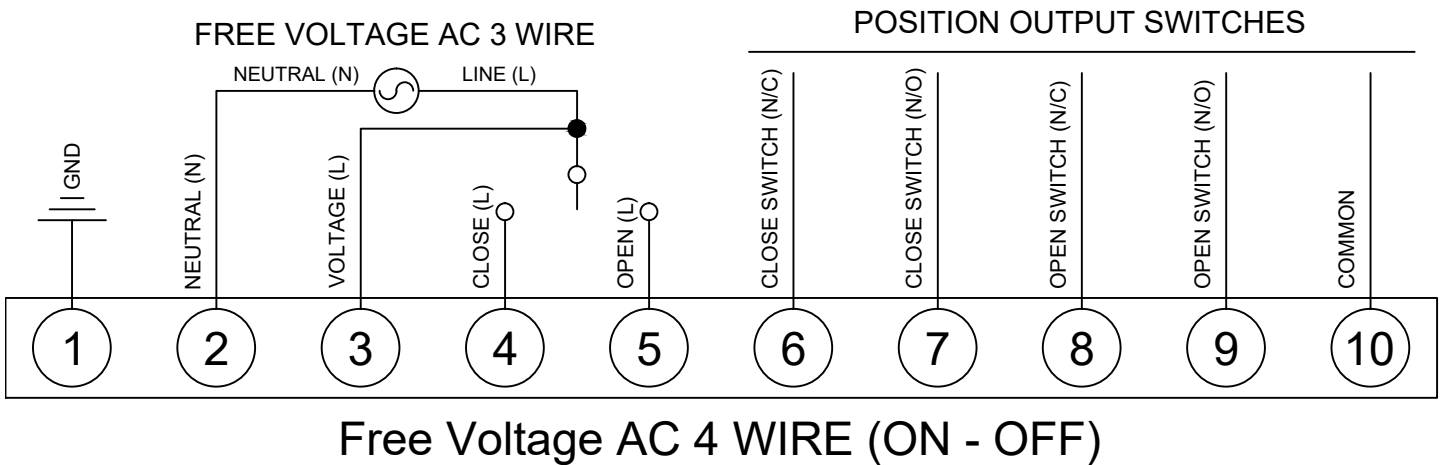
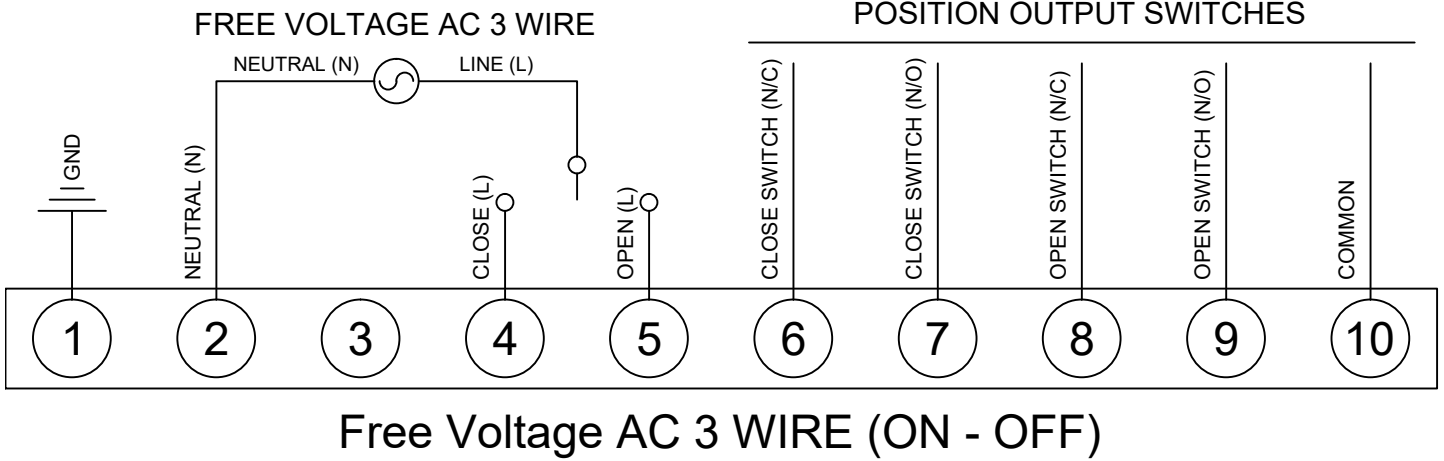



d. Wiring Diagram

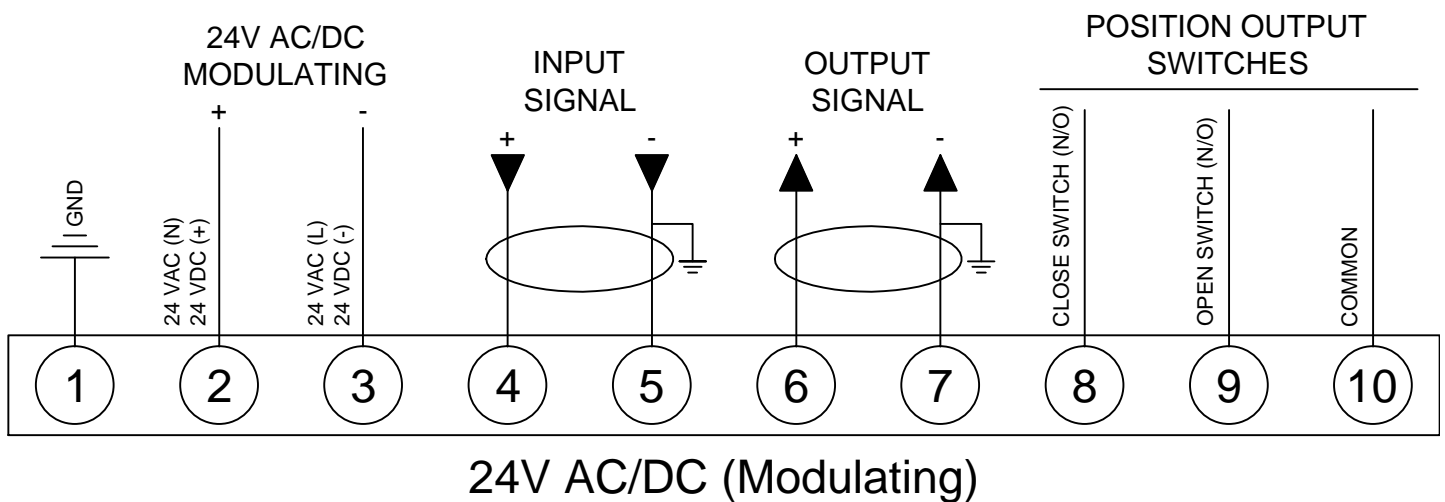
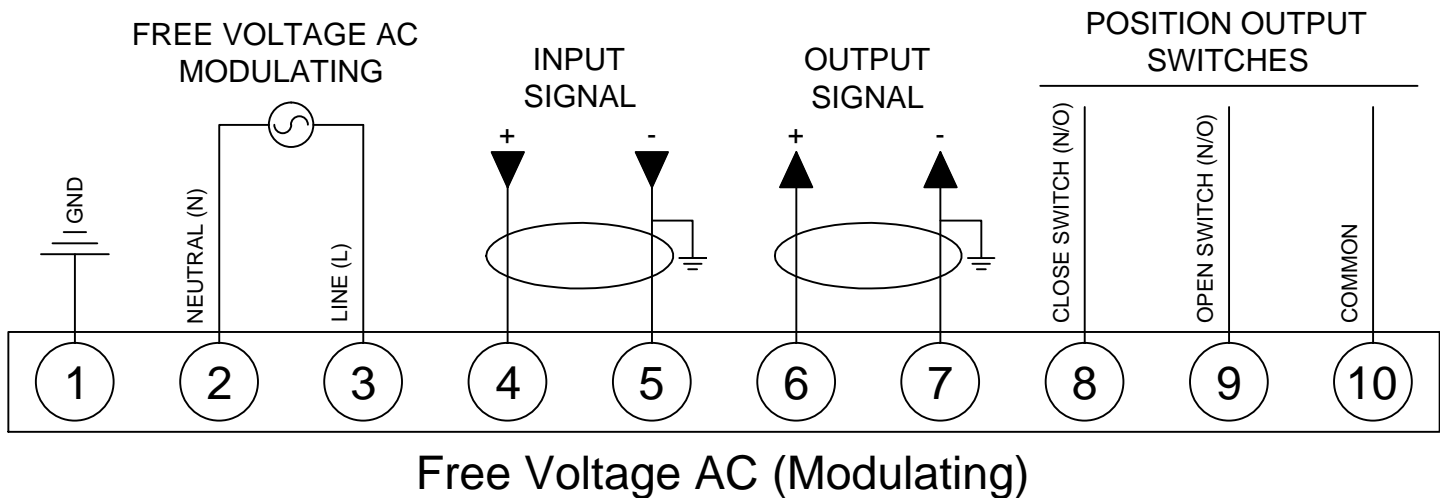
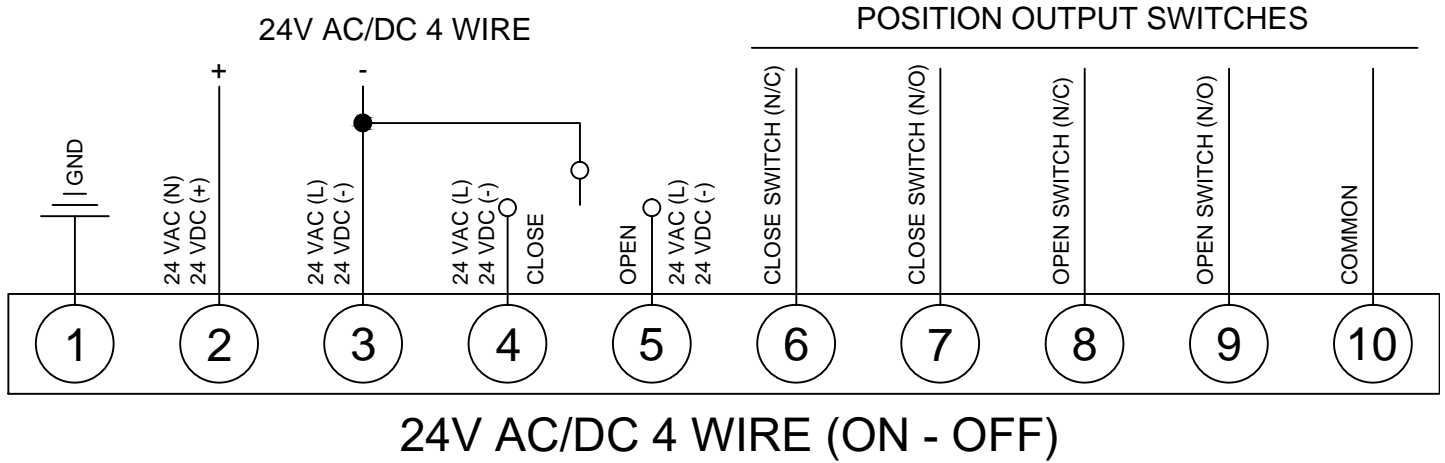

## POWER SUPPLY : 3P+T DIN43650 CONNECTOR SUGGESTED CUSTOMER WIRING

---

### 3-Position Switch Control (Open/Close)

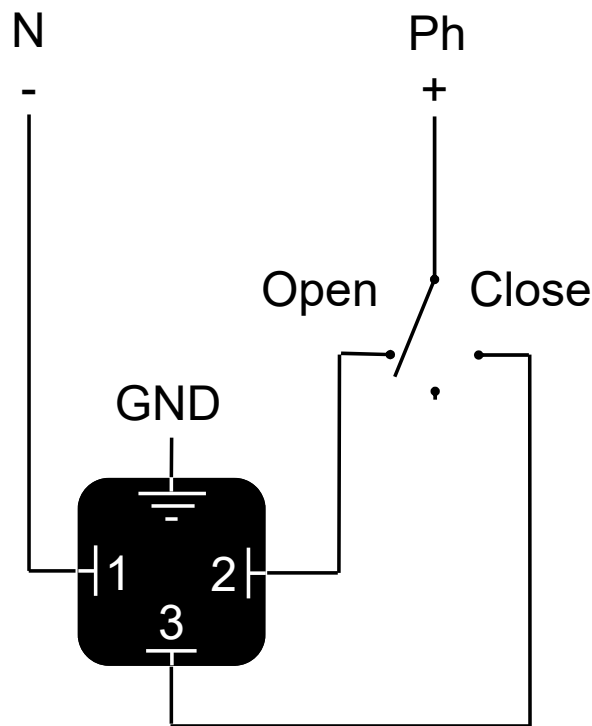

---

### DIN Wiring for Modulating Option

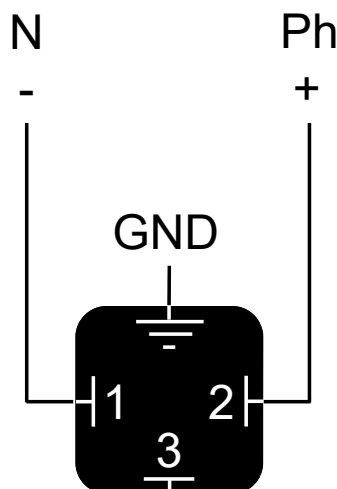

### C. Limit switch setting

(1) No need to adjust because Limit Switch is set at factory.

(2) In case that Limit Switch Cam re-adjust at site, operate the actuator manually to the close(open) position.

- Loosen the cam adjustment screw in the Close(Open) limit switch cam.
- Rotate the cam in a clockwise(counter-clock wise) towards the limit switch lever until cam double-clicks on the switch.
- Tighten the cam screw

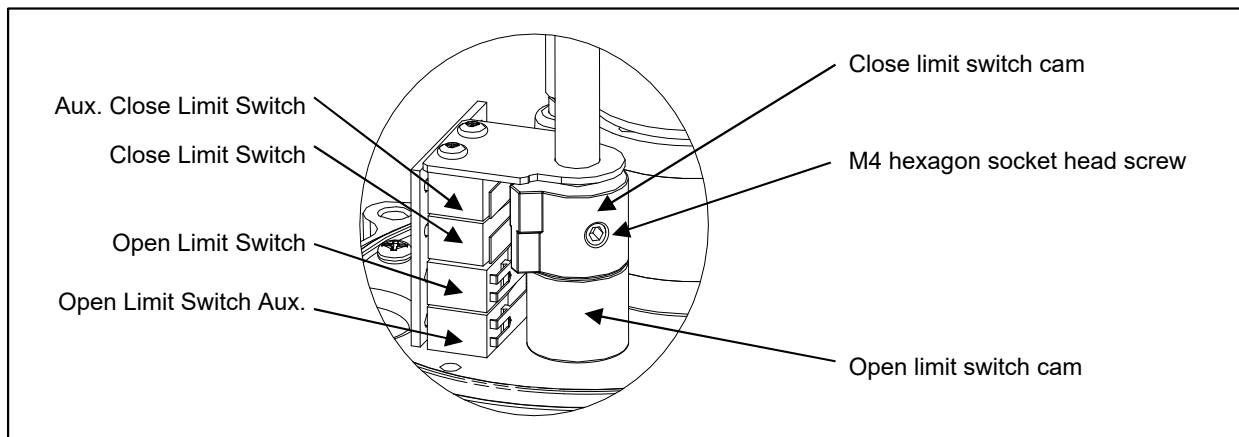

### D. Manual operation

- (1) Disconnect Power
- (2) Rotate lever 90° as the right picture.
- (3) Rotate handle-wheel for open or close
- (4) **After manual operation or supplying power, place the lever back in place !!!**

※ When turning the lever, simultaneously turn the handle slightly in both directions.

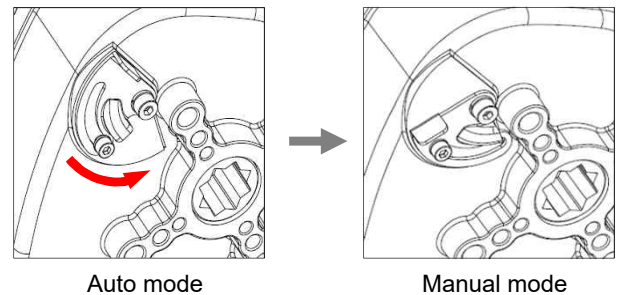

### 7. Trouble Shooting

#### A. Actuator does not respond

- (1) Check that the voltage matches the rating on the actuator nameplate.
- (2) Verify the line of power supplying to the actuator
- (3) Check internal wiring against actuator wiring diagram
- (4) Check limit switch cams

#### B. Actuator is receiving power but does not operate

- (1) Check if the valve force is bigger than the torque of actuator
- (2) Check limit switches and cams
- (3) Check internal wiring
- (4) Verify coupler/bracket are correctly installed
- (5) Verify the actuator against valve rotation

#### C. Valve only opens or closes partially with motor

- (1) Limit switch incorrectly set
- (2) Over torque : Incorrectly sized actuator
- (3) Jammed valve
- (4) Damaged or bent valve stem

## 8. Maintenance

### A. Lubrication

Lubrication is already done by factory and generally no need field lubricate.

In places such as very dry condition below 15% Rh or high temperature higher than 30°C, it is required to lubricate every two years through Grease nipple.

### B. Regular operation

Even if you do not use an actuator, electrical power always should be supplied to actuator and it is recommended to operate actuator once a week

### C. Maintenance

Actuator should be thoroughly checked at least once a year.

- Disconnect all power to actuator.
- Check that all external bolting and mounting to the valve is secure and aligned.
- Check to see that conduit connections are installed properly and are dry.
- Open Electrical Enclosure.
- Visually inspect for cleanliness and any electrical or mechanical damage.
- Inspect for excess moisture and condensation inside the electrical enclosure.
- Confirm that wiring is insulated, connected and terminated properly.
- Check enclosure O-ring seals and verify that the O-ring is not pinched between the flanges.
- Visually inspect during open/close cycle.

## 9. Instruction of PCU Card

### A. Layout of PCU

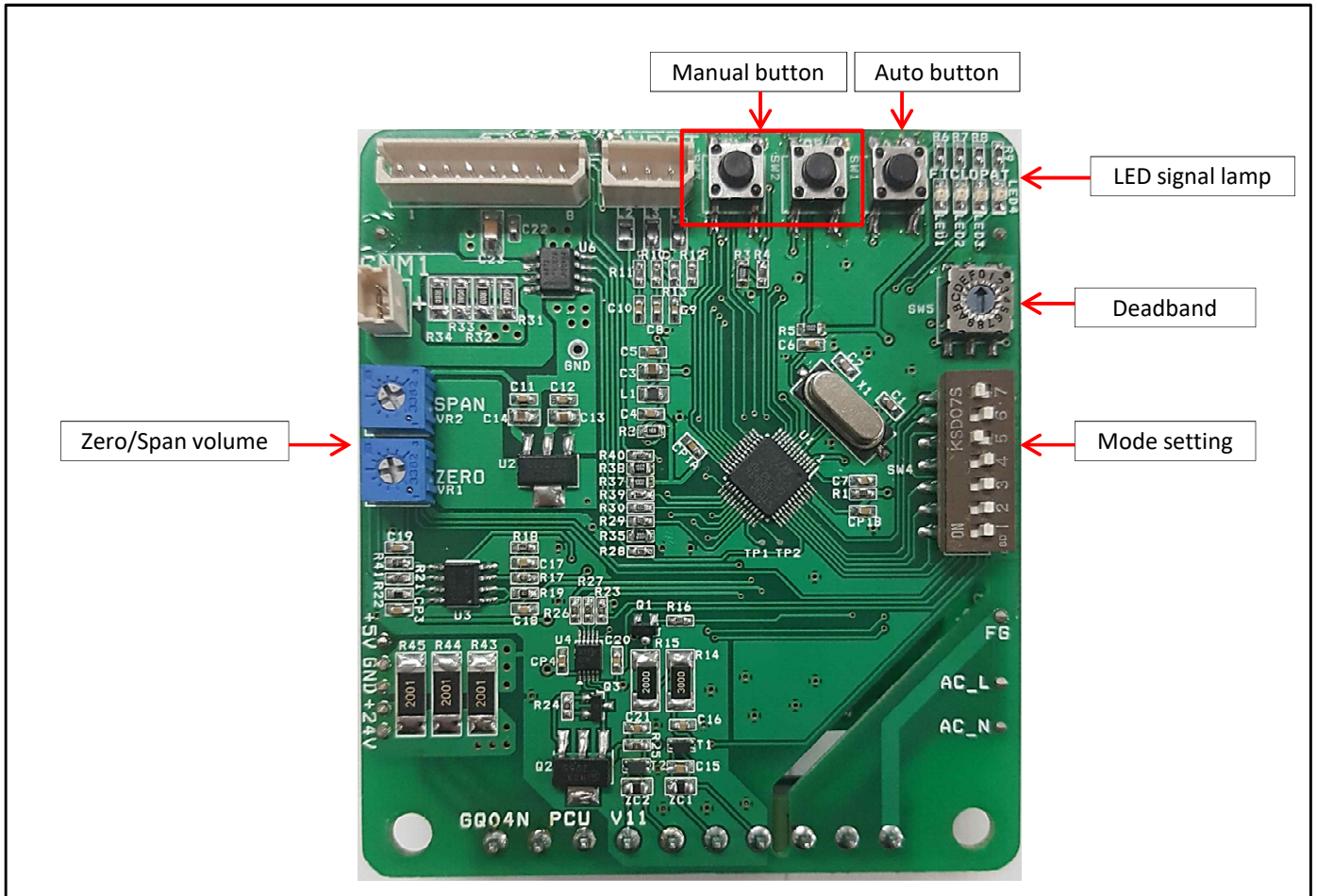

### B. Specification of PCU

Supplying Electric Power	95 to 245 VAC 50/60Hz (1Ph), 24 VAC 50/60Hz, & 24 VDC
Input Signal	4~20mA, 0~10V, 2~10V
Output Signal	4~20mA, 0~10V, 2~10V
Insulation Resistance	500V DC, 50Mohm
Space Heater	1W
Input Position Conversion Accuracy	± 1%
Output Position Conversion Accuracy	± 1%
Ambient Temperature	-4° F to 140° F (-20° C to +60° C)
Ambient Humidity	90% RH Max. (non-condensing)

### C. Mode setting (Setting of Dip switch)

INPUT		OUTPUT			FAIL		MODE
SW-1	SW-2	SW-3	SW-4	SW-5	SW-6	SW-7	
ON	OFF						MANUAL
OFF	ON						AUTO
OFF	OFF	OFF	OFF	ON			4~20mA
OFF	ON	OFF	OFF	ON			2-10VDC
ON	ON	ON	ON	OFF			0-10VDC
					OFF	OFF	STOP
					ON	OFF	OPEN
					OFF	ON	CLOSE

### D. Modulating Set-Up

#### 1. Auto mode

- DIP S/W "1" is OFF.
- Push "Auto button" around 3seconds
  - To minimize hunting and improve resolution, operate 3 times around 0~10% range in close position and operate 3 times around 90~100% range in open position.

※ Actuator do not respond to input signal or manual mode during auto mode.

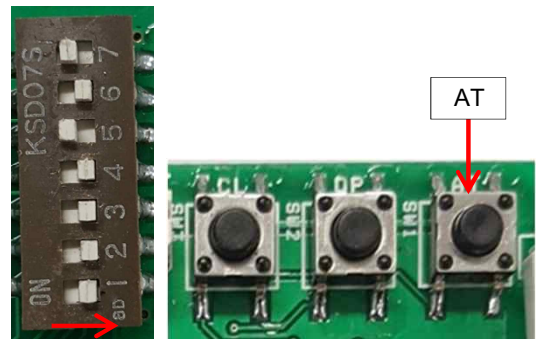

#### 2. Manual mode

- DIP S/W "1" is ON.
- For open, push "OP" button and push "CL" for close.

※ Actuator do not respond to input signal during manual mode.

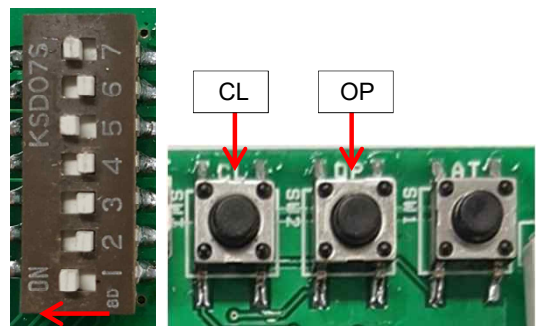

### 3. Setting of In/Output signal

SIGNAL	INPUT		OUTPUT		
	SW-1	SW-2	SW-3	SW-4	SW-5
4~20mA	OFF	OFF	OFF	OFF	ON
2-10VDC	OFF	ON	OFF	OFF	ON
0-10VDC	ON	ON	ON	ON	OFF

### 4. Adjustment of Output signal

Adjust zero or span volume switch to meet the exact value of output signal in accordance with input signal value.



### 5. LED Signal Lamp

#### 1) LED

Status	FT(RED)	CL(YEL)	OP(GRE)	AT(RED)
Normal operation	ON			
Auto setting		ON	ON	ON
Opening			ON	
Closing		ON		

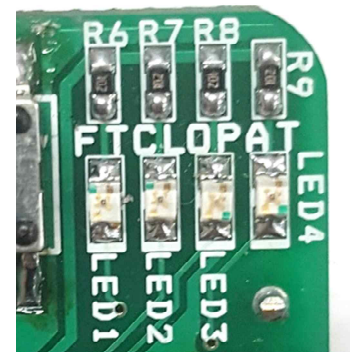

#### 2) LED for error

Error	LED	Status
Potentiometer fault	LED1 & LED2	ON
	LED3 & LED4	Blink every 0.5 sec
Broken input signal	LED1 & LED2	ON

### 6. Dead band setting

It is set to adjust the accuracy of the input signal.

0 step : Set as factory default

1 step : 0.1mA

Increase by 0.05mA for each step(2 ~ F step)

If the accuracy is too high, it could cause "HUNTING". HUNTING means the actuator doesn't stop at the right position and repeats open or close to find the right position.

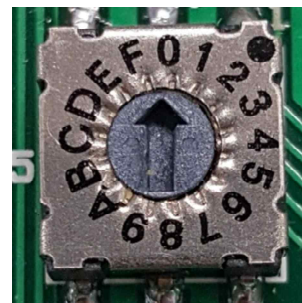

HUNTING might be the reason of the motor burning and damages of the potentiometer and PCU card.

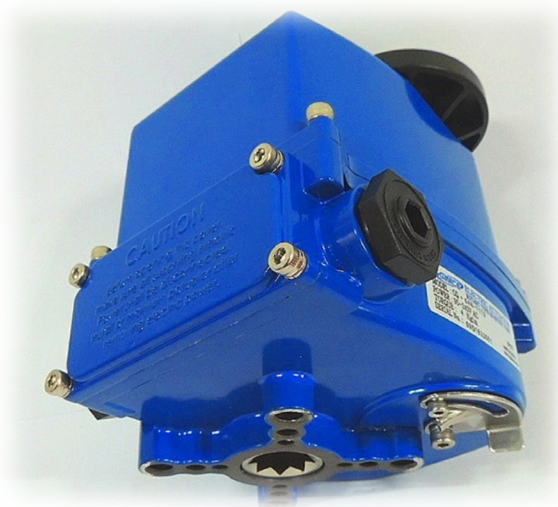

---

CR-TEC reserves the right to change or remove products or services from its range at any time and without prior notification or obligation. CR-TEC does not assume any liability for consequences resulting from the use of this document. There is no guarantee that the information provided here is complete, accurate or up to date.

---

## **CR-TEC Engineering Inc.**

**CR-TEC Engineering Inc.**

15 Orchard Park Road, Unit 18  
Telephone 203-318-9500 • Fax 203-245-2575  
info@crtec.com • www.crtec.com