

REVISION	DESCRIPTION	DATE	APPROVED
A	Initial Release	9/17/19	CWL

DIMENSIONS

SIZE	Ød	L	E	H	D	A	ISO 5211		ØM	ØN
							(1)	(2)		
1/4"	11	78.9	131	66	9	8.1	F04	F03	6	6
							42	36		
3/8"	11	78.9	131	66	9	8.1	F04	F03	6	6
							42	36		
1/2"	15	78.9	131	66	9	8.1	F04	F03	6	6
							42	36		
3/4"	20	94.4	131	73	9	9	F04	F03	6	6
							42	36		
1"	25	96.3	184	91	11	11.5	F05	F04	7	6
							50	42		
1 1/4"	32	109.3	184	96	11	11.5	F05	F04	7	6
							50	42		
1 1/2"	38.1	120.3	227	110	14	14.5	F07	F05	9	7
							70	50		
2"	50	138.4	227	119	14	15	F07	F05	9	7
							70	50		

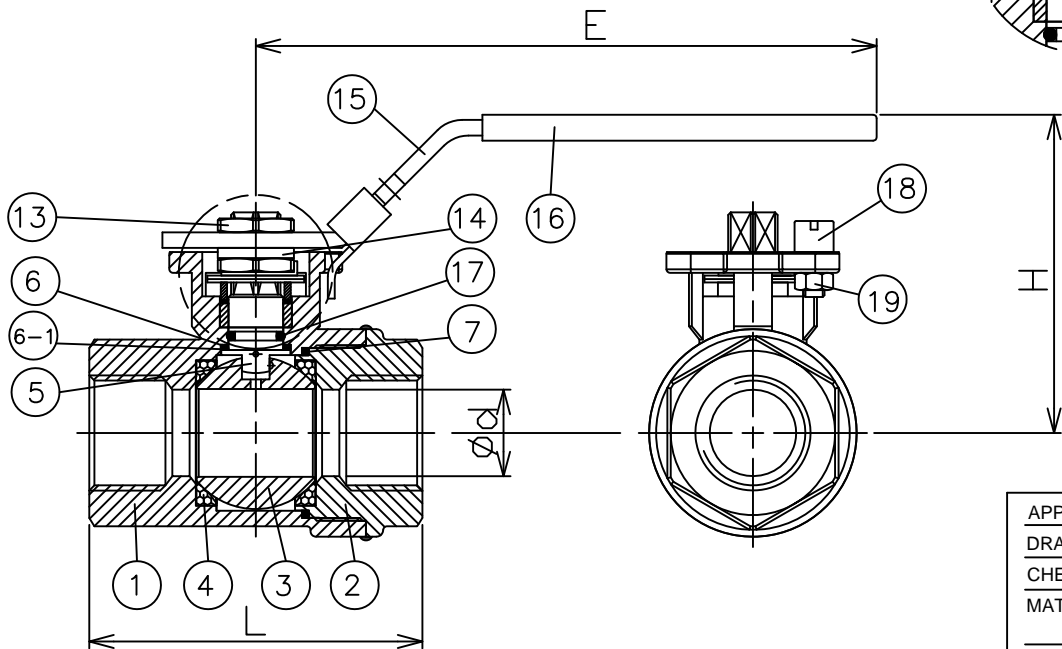
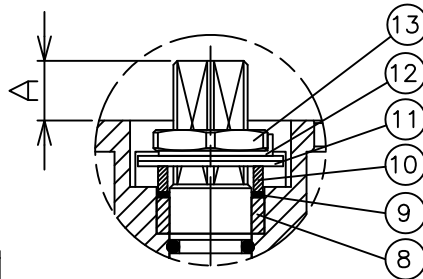
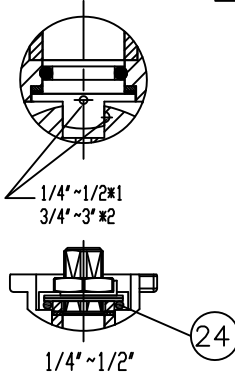
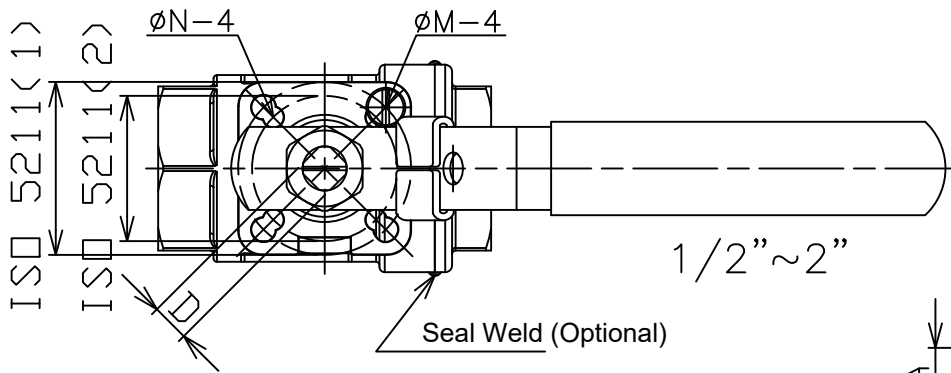

MATERIAL LIST

NO	DRAW NO	PART NAME	MATERIAL	QTY
1	01	BODY	ASTM A216 WCB/A351 CF8M	1
2	02	CAP	ASTM A216 WCB/A351 CF8M	1
3	03	BALL	ASTM A351 Gr. CF8M	1
4	04	BALL SEATS	DELRIN/PEEK	1 SETS
5	05	STEM	17-4PH	1
6	06	THRUST WASHER	GRAPHITE	1
6-1	06-1	THRUST WASHER	PTFE	1-2
7	07	END SEALS	PTFE	1
8	08	STEM PACKING	GRAPHITE	1
9	09	THRUST WASHER	TFM1600	1
10	10	GLAND BUSH	S. S. 304	1
11	11	BELLEVILLE WASHER	SUS304-CSP	2
12	12	STOP	S. S. 304	1
13	13	HANDLE NUT	S. S. 304	2
14	14	WASHER	S. S. 304	1
15	15	HANDLE	S. S. 304	1
16	16	HANDLE SLEEVE	VINYL GRIP	1
17	17	O-RING	VITON	1
18	18	STOPPER	S. S. 304	1
19	19	NUT	A2-70	1
24	24	GROUNDING SPRING	S. S304	1

APPROVALS	DATE
DRAWN	9/17/19
CHECKED	
MATERIAL	
Stainless, DELRIN/PEEK	
FINISH Standard Machine Finish	
UNLESS OTHERWISE SPECIFIED DIMENSIONS ARE IN MILLIMETERS	
DECIMALS	ANGLES
X.X=+/- .025"	+/- 5 degrees
X.XX=+/- .010"	
X.XXX=+/- .002"	

CR-TEC Engineering Inc.

15 Orchard Park Road ~ Unit 18 - Madison, CT 06443
 Phone (203) 318-9500 - www.crtec.com

3600 psi Ball Valve
 CRS329HPS (DELRIN)
 CRS429HPS (PEEK)

SCALE: None

PROPRIETARY ITEM of CR-TEC Engineering Inc. Do not copy drawing or transfer to others without express permission from CR-TEC Engineering Inc..