

CRS823F

2-Way Ball Valve with Mounting Pad

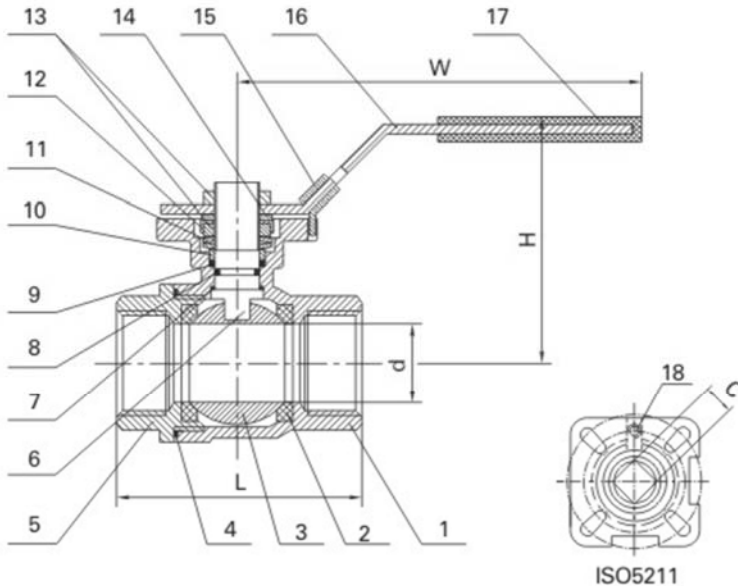

- Investment Cast Body and Cap
- Full Bore
- Threaded Ends: ANSI B2.1, BS21, ISO7/1
- Mounting Pad: ISO5211
- Pressure Rating: 1000 PSI (PN63)
- Working Temperature: -25°C +180°C
- Material: CF8M, CF8, CF3M, WCB



MATERIAL LIST

ITEM	PART	MATERIAL	QTY.
1	Body	CF8M	1
2	Ball Seat	R-PTFE(15%)	2
3	Ball	SS316	1
4	Body Gasket	PTFE	1
5	Cap	CF8M	1
6	Stem	SS316	1
7	Thrust Washer	PTFE	1
8	O-Ring	VITON	1
9	Stem Packing	PTFE	1
10	Stem Ring	SS316	1
11	Belleville Washer	SS301	2
12	Nut Stopper	SS304	1
13	Nut	SS304	2
14	Plate Washer	SS304	1
15	Lock Device	SS304	1
16	Handle	SS304	1
17	Plastic Cover	PLASTIC	1
18	Stop Pin	SS304	1

PRESSURE-TEMPERATURE RATING

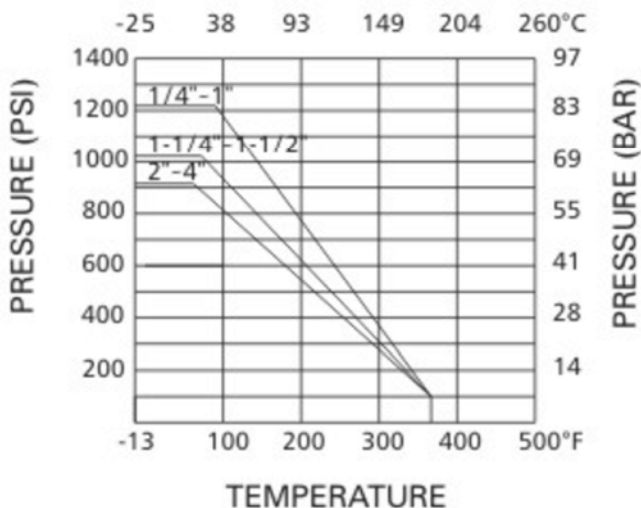

DIMENSION LIST

SIZE	d	L	H	W	C	ISO5211	N-m	Kgs
1/4"	11.5	56	65	115	9	F03	5	0.37
3/8"	12.5	56	65	115	9	F03	5	0.35
1/2"	15	57	65	117	9	F03/F04	5	0.37
3/4"	20	64	70	117	9	F03/F04	8	0.49
1"	25	77	75	134	11	F04/F05	10	0.74
1-1/4"	32	90	85	134	11	F04/F05	14	1.18
1-1/2"	40	105	95	203	14	F05/F07	18	1.94
2"	50	125	105	203	14	F05/F07	25	2.90
2-1/2"	65	153	140	255	17	F07/F10	48	5.77
3"	76	172	145	255	17	F07/F10	75	8.45
4"	94	221	175	302	17	F07/F10	110	15.60