

CR-TEC Engineering

Automated Valve Solutions

CRS833F

3-pc DIN Length 2-Way Ball Valve with Mounting Pad

*CRS835F - 50/50 Seat Option (50% PTFE & 50% Stainless Steel)

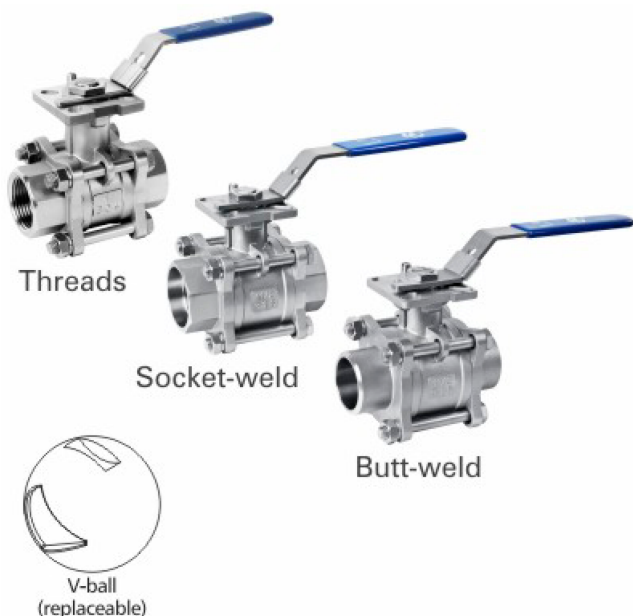

- Investment casting for body and cap
- Full bore
- Thread: ISO, BS, DIN, JIS, ASME
- Mounting pad: ISO 5211
- Length: DIN3202-M3(MV-33/33S)
DIN3202-S13(MV-33B)
- Pressure rating: 1000PSI (PN63)
- Working temperature: -25°C ~ +180°C
- Material: CF8M, CF8, CF3M, WCB

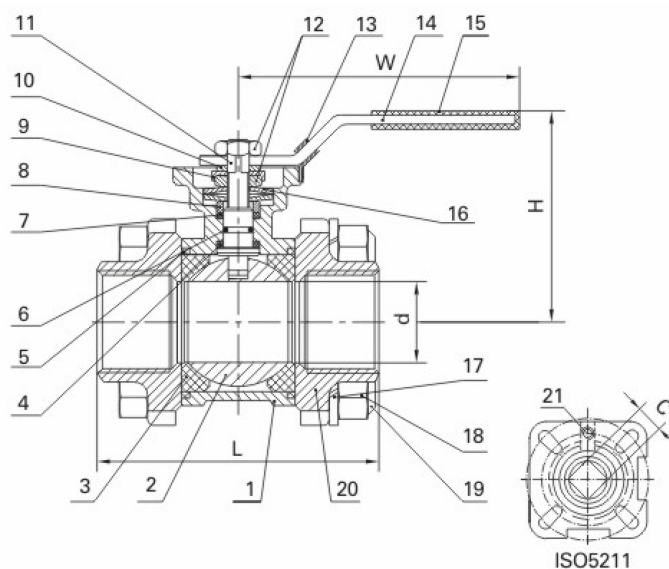
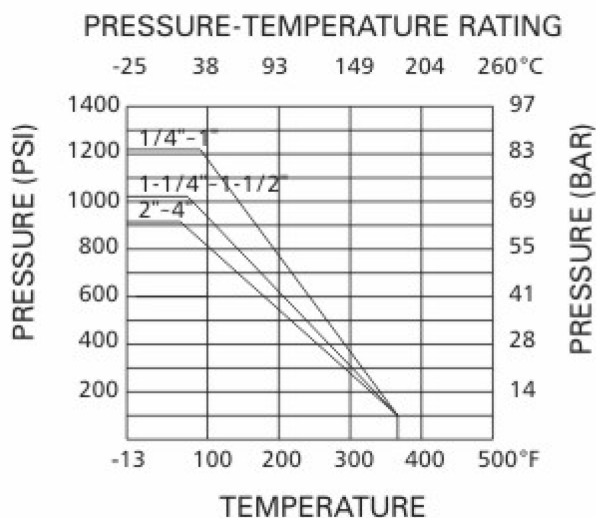

MATERIAL LIST

ITEM	PARTS	MATERIAL	QTY.
1	Body	CF8M	1
2	Ball	SS316	1
3	Ball Seat	R-PTFE(15%)	2
4	Thrust Washer	PTFE	1
5	Body Gasket	PTFE	2
6	O-Ring	VITON	1
7	Stem Packing	PTFE	1
8	Stem Ring	SS316	1
9	Nut Stopper	SS304	1
10	Plate Washer	SS304	1
11	Stem	SS316	1
12	Nut	SS304	2
13	Lock Device	SS304	1
14	Handle	SS304	1
15	Handle Cover	PLASTIC	1
16	Belleville Washer	SS301	2
17	Spring Washer	SS304	4(12)
18	Nut	SS304	4(12)
19	Bolt	SS304	4(6)
20	Cap	CF8M	2
21	Stop Pin	SS304	1

DIMENSION LIST (Threads)

SIZE	d	L	H	C	W	ISO5211	N-m	Kgs
1/4"	11	50	59	9	115	F03	4	0.46
3/8"	12.5	60	59	9	115	F03	4	0.48
1/2"	15	75	70	9	117	F03/F04	5	0.50
3/4"	20	80	78	11	134	F04/F05	8	0.89
1"	25	90	87	11	134	F04/F05	10	1.28
1-1/4"	32	110	98	14	203	F05/F07	14	1.99
1-1/2"	40	120	104	14	203	F05/F07	18	2.96
2"	50	140	112	14	203	F05/F07	25	3.75
2-1/2"	65	185	140	17	255	F07/F10	48	7.80
3"	80	205	153	17	255	F07/F10	75	12.40
4"	100	240	166	17	302	F07/F10	110	20.80