

# CR-TEC Engineering

Automated Valve Solutions

## CRSF150 (ANSI-150)

## CRSF300 (ANSI-300)

### 2-pc Flanged 2-Way Ball Valve

- Investment Cast Body and Cap
- Full bore
- Optional Fire-Safe Design (Graphite Body Seal)
- Flanged Ends: ANSI B16.5
- Face to Face: ANSI B16.10
- Mounting Pad: ISO5211
- Pressure Rating: 150 LB / 300 LB
- Working Temperature: - 25°C + 180°C
- Material: CF8M, CF8, CF3M, WCB
- Seat Options: R-PTFE, PTFE (Fire-Safe)

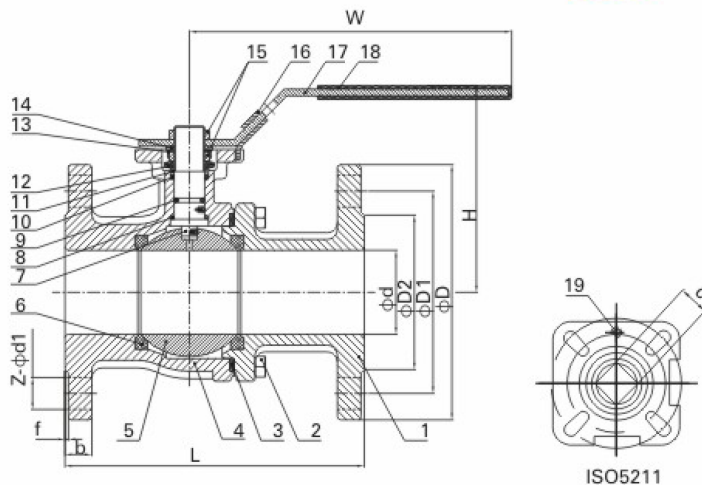

(5"~8")

### PRESSURE-TEMPERATURE RATING

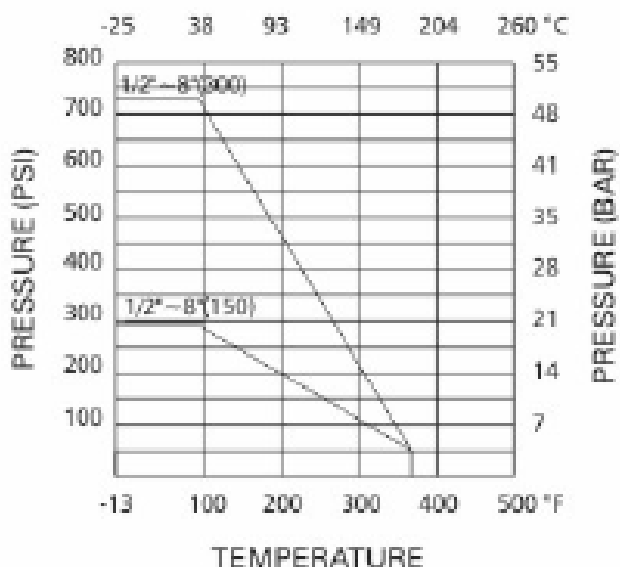

### MATERIAL LIST

ITEM	PART	MATERIAL	QTY.
1	Cap	CF8M	1
2	Bolt	SS304	4/8/12
3	Body Gasket	PTFE	1
4	Body	CF8M	1
5	Ball	SS316	1
6	Ball Seat	R-PTFE(15%)	2
7	Stem	SS316	1
8	Thrust Washer	PTFE	1
9	O- Ring	VITON	1
10	Stem Packing	PTFE	1
11	Stem Ring	SS316	1
12	Belleville Washer	SS301	2
13	Nut Stopper	SS304	1
14	Plate Washer	SS304	1
15	Nut	SS304	2
16	Lock Device	SS304	1
17	Handle	SS304	1
18	Plastic Cover	PLASTIC	1
19	Stop Pin	SS304	1

### DIMENSION LIST

SIZE	CL	d	L	D	D1	D2	b	f	H	W	C	ISO5211	Z-φd1	N-m
1/2"	150Lb	15	108	89	60.5	35	11	2	82	117	9	F03/F04	4-φ15	5
	300Lb	140	95	66.5			14.5							
3/4"	150Lb	20	117	98	70	43	11	2	87	117	9	F03/F04	4-φ15	8
	300Lb	152	117	82.5			16						4-φ19	
1"	150Lb	25	127	108	79.5	51	12	2	90	164	11	F04/F05	4-φ15	10
	300Lb	165	124	89			17.5						4-φ19	
1-1/4"	150Lb	32	140	117	89	64	13	2	100	164	11	F04/F05	4-φ15	14
	300Lb	178	133	98.5			19.5						4-φ19	
1-1/2"	150Lb	40	165	127	98.5	73	15	2	116	203	14	F05/F07	4-φ15	18
	300Lb	190	156	114.5			21						4-φ22	
2"	150Lb	50	178	152	120.5	92	16	2	125	203	14	F05/F07	4-φ19	25
	300Lb	216	165	127			22.5						8-φ19	
2-1/2"	150Lb	65	190	178	139.5	105	18	2	164	255	17	F07/F10	4-φ19	48
	300Lb	241	190	149			25.5						8-φ22	
3"	150Lb	80	203	190	152.5	127	19	2	174	255	17	F07/F10	4-φ19	75
	300Lb	283	210	168.5			29						8-φ22	
4"	150Lb	100	229	229	190.5	157	24	2	200	302	17	F07/F10	8-φ19	110
	300Lb	305	254	200			32						8-φ22	
5"	150Lb	125	356	254	216	186	24	2	260	600	22	F10/F12	8-φ22	200
	300Lb	381	279	235			35						8-φ22	
6"	150Lb	150	394	279	241.5	216	26	2	278	600	22	F10/F12	8-φ22	300
	300Lb	403	318	270			37						12-φ22	
8"	150Lb	200	457	343	298.5	270	29	2	340	800	27	F12/F14	8-φ22	400
	300Lb	502	381	330			41.5						12-φ25	