

CR-TEC Engineering

Automated Valve Solutions



Concentric Butterfly Valves

CRV3 Series

Wafer, Lug & Flanged

► Technical Data

Manufacturing range	DN32 – DN2000
Face to face	EN 558 Series 20
	ISO 5752 Series 20
	API 608 Table 1
	BS 5155 Series 4
Mounting between	PN10/16-ANSI150 Lbs.
Flanges	ISO 7005, DIN 2501, BS 4504
	ANSI Class 150: ANSI B16.5
Top Flange	ISO 5211
Tightness Test	ISO 5208, zero leakage
	API 598
Coating	Rilsan®
Working Pressure	DN32 – DN600, Max. 20 bar
	>DN600, Max. 16 bar



► Features

- Valves certified and approved for different applications.
- 100% tight shut off, 0% leakage.
- Replaceable or vulcanized seat.
- One piece dry shaft. The fluid is not in contact with either the shaft or the body.
- Bi-directional sealing.
- Self-cleaning.
- Lightweight design for easier installation.
- Easy maintenance.
- Possibility of operation through different manual controls (hand lever, gearbox...), electric, pneumatic, hydraulic actuator,...
- Low operation torque.
- Aerodynamic butterfly design that minimizes pressure drop.

► General Applications

Water:

- Irrigation
- Potable water
- Sea water
- Water supply
- Pumping station
- Industrial water
- Waste water
- Fire protection systems
- Cooling tower

Industry:

- Food
- Paper mills
- Chemical
- Petrochemical
- Sugar mills
- Cement industry
- Petroleum
- Steel industry

Power generation

Shipbuilding and offshore

Mining

Heating

Air conditioning

Compressed air

Construction



ATTESTATION DE CONFORMITE
SANITAIRE
14AGGLY 011



FDA SEATS
Test Report:
891/13/9797 M1



APSAD
N°Ref.: P.J.NG/RB/10.10/VAN.045



FDA
CODE OF FEDERAL
REGULATIONS 21 CFR



ATEX
2014/34/UE



TYPE APPROVAL
MARINE & OFFSHORE DIVISION
CERTIFICATE No. 14ETCO 017



N° ROB 064



ROB-GAZ



DNV



CERTIFICATE OF CONFORMITY
N° TC RU-CE-EMKQ 2 02152
N° 1020542



CERTIFICATE OF APPROVAL QUALITY
MANAGEMENT SYSTEM STANDARD
ISO 9001:2008
No.: 501 2202208



EC CERTIFICATE OF CONFORMITY
DIRECTIVE 2002/95/EC
CERTIFICATE No.: 004020401018



FIRE SAFE TEST
FOR VALVES



CE
2014/68/UE

Torque valves (Nm)

DN		Torque (Nm)		
mm	in	6 bar	10 bar	16 bar
32	1 1/4"	3	6	9
40	1 1/2"	3	6	9
50	2"	5	8	11
65	2 1/2"	7	10	20
80	3"	10	14	29
100	4"	12	18	47
125	5"	18	31	82
150	6"	31	59	130
200	8"	55	93	210
250	10"	123	206	360
300	12"	216	330	475
350	14"	333	425	760
400	16"	519	640	1300
450	18"	735	1176	1600
500	20"	931	1450	2340
600	24"	1372	2850	3300
700	28"	2254	4600	6250
750	30"	3136	5800	7644
800	32"	3724	7400	8938
900	36"	4410	11000	11760
1000	40"	6223	13600	15876
1100	44"	9702	14200	18535
1200	48"	12150	16400	21000
1300	52"	-	17800	-
1400	56"	-	19200	-
1600	64"	-	29000	-

All torque valves shown in the chart are for wet (water and other non-lubricating media) on-off service. For dry services (non-lubricating, dry gas media) multiply the values by 1.15
For lubricous services (clean, non-abrasive lubricating media) multiply values by 0.85

Please contact technical department for additional data/info.

Kv data

Flow coefficient Kv
90°
70
70
164
201
359
627
995
1471
2509
3936
5865
8179
10660
12889
16023
22741
32448
35033
44850
51247
66104
81526
97355
119787
138400
166080

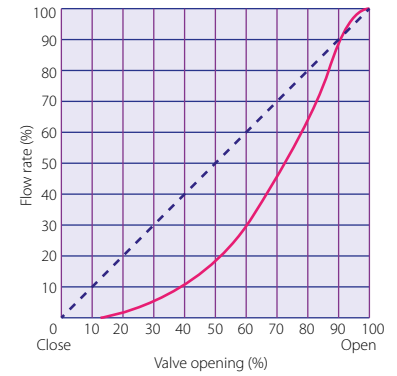

$$Cv = 1.16 \cdot Kv$$

Kv: Volume of water in m³/h, that will flow through a given restriction or valve opening with a pressure drop of 1 bar at 20°C

Chart for temperature and resistance:

Name	Applications	Limitations	Temp. Rating
EPDM	Water, sea water, alcohols, organic salts dissolutions, mineral acid solutions, mineral bases alkaline	Not recommended for organic hydrocarbons	-20°C to 110°C
High Temp. EPDM	Water	Not recommended for hydrocarbons	-20°C to 130°C
NBR	Mineral and vegetable oils, gas, non-aromatic hydrocarbons, animal fats, vegetable fats, air	Organic acids, some mineral acids, chlorine, alcohols, aromatic hydrocarbons	-10°C to 80°C
Hypalon	Mineral acid dissolutions, organic and inorganic acids, oxidizing substances	Mineral and vegetable oils, hydrocarbons, animal and vegetable fats, cetones	-10°C to 80°C
FKM	Acids, fats, hydrocarbons, vegetable and mineral oils, fuels	Steam and hot water (max. 130°C) unleaded gasoline, cetones, amines, freon 22	-5°C to 180°C
Silicone	Low and high temperature resistance, food grade	Hydrocarbons, acids, bases, atmospheric agents	-10°C to 160°C
High Temp. Silicone	Superheated	Hydrocarbons, strong acids and strong bases	-50°C to 160°C
Epiclorhidrine	Ozone resistance, hydrocarbons, aromatic oils	Steam, intermediate resistance to oils	-25°C to 145°C

How to order: Ex.: CRV3209040B-6W

Body Material		Stem Material		Disc Material		Valve Type		Seat Material		Body Series	
20		90		40				B		W	
10	GJL250	30	AISI 304	20	GJS500-7		Concentric standard soft seated	C	NATURAL RUBBER	W	Wafer
20	GJS500-7	40	AISI 316	40	CF-8M	V	Vulcanized seat	E	EPDM	L	Lug
40	CF-8M	90	AISI 420	50	WCB			EA	DRINKING WATER EPDM	B	Flanged
50	WCB	95	17-4 PH	80	B-148 C95500			ET	HIGH TEMPERATURE EPDM		
51	LCB	D0	1.4462	91	CA-15			EN	NORDEL		
60	Aluminium	D1	1.4517	95	17-4 PH						
80	B-148 C95500	M5	MONEL K-500	D0	1.4470			H	HYPALON		
				D1	1.4517			B	BUNA (NITRILE)		
				H0	HASTELLOY C			NC	CARBOXYLATED NITRILE		
				U0	URANUS B6			NG	GAS NITRILE		
				S3	1.4469			NL	LOW TEMPERATURE NITRILE		
				S7	CK3MCuN			S	SILICONE (VQM)		
								SA	FOOD GRADE SILICONE		
								ST	HIGH TEMPERATURE SILICONE		
								V	FKM (KNOWN AS VITON)		
								ST	EPICHLOROHYDRIN (ECO)		
								PU	POLYURETHANE		

Wafer

▶ Valve dimensions

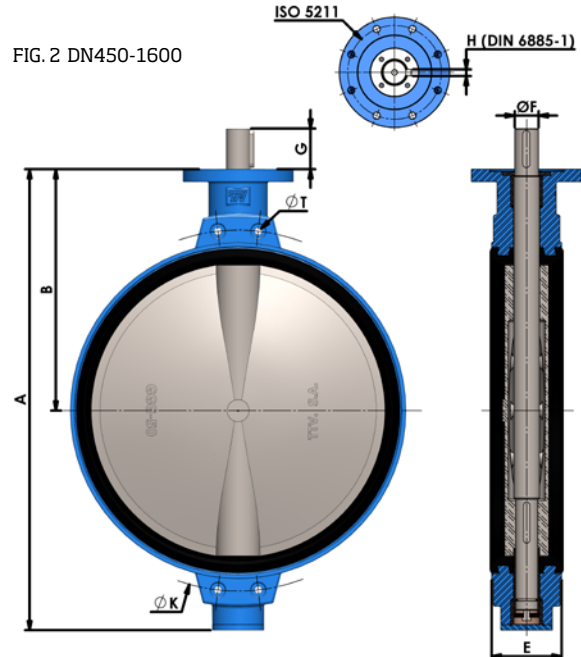
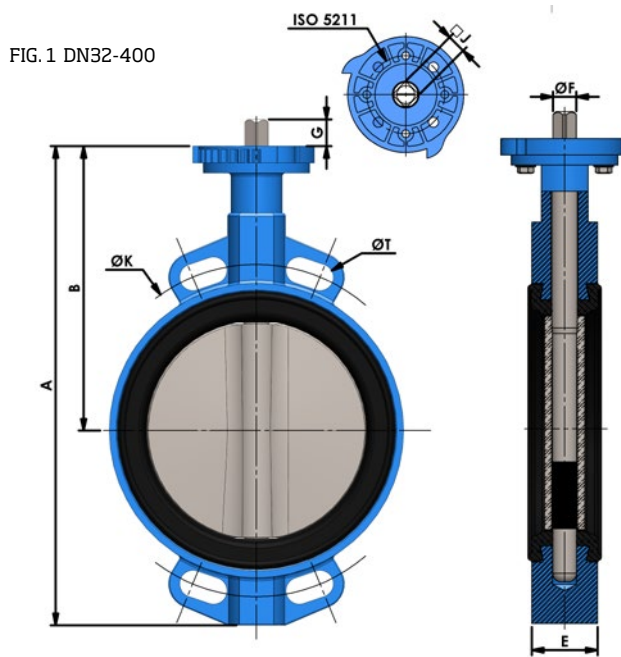

Valves dimensions										PN10		PN16		ANSI150	
DN		A	B	E	F	G	J	ISO 5211	Weight (Kg)	K	Holes N°xT	K	Holes N°xT	K	Holes N°xT
mm	In														

FIG. 1 DN32-400

32	1 1/4"	206	140	33	9,8	14	8	F05/07	2	100	4x18	100	4x18	88,9	4x16
40	1 1/2"	206	140	33	9,8	14	8	F05/07	2	110	4x18	110	4x18	98,5	4x16
50	2"	228	156	43	9,8	14	8	F05/07	3,5	125	4x18	125	4x18	120,6	4x19
65	2 1/2"	248	161	46	12	16	9	F05/07	4,5	145	4x18	145	4x18	139,7	4x19
80	3"	265	169	46	14	16	11	F05/07	5	160	4x18	160	4x18	152,4	4x19
100	4"	298	187	52	14	20	11	F05/07	6,5	180	4x18	180	4x18	190,5	4x19
125	5"	331	206	56	18	20	14	F07	8	210	4x18	210	4x18	215,9	4x23
150	6"	349	215	56	18	20	14	F07	9	240	4x23	240	4x23	241,3	4x23
200	8"	430	255	60	22	24	17	F07	15	295	4x23	295	4x23	298,5	4x23
250	10"	461	248	68	25	24	19	F10	21,5	350	4x23	355	4x27	362	4x26
300	12"	524	280	78	28	24	22	F10	30	400	4x23	410	4x27	431,8	4x26
350	14"	570	300	78	28	29	22	F14	39	460	4x23	470	4x27	476,3	4x29
400	16"	644	340	102	35	29	27	F14	52	515	4x27	525	4x30	539,8	4x29

FIG. 2 DN450-1600

450	18"	736	390	114	50	80	-	F14	87	565	4xM24	585	4xM27	577,9	4x1 1/8"
500	20"	825	440	127	50	80	-	F14	117	620	4xM24	650	4xM30	635	4x1 1/8"
600	24"	965	507	154	60	90	-	F16	177	725	4xM27	770	4xM33	749,3	4x1 1/4"
700	28"	1100	575	165	60	90	-	F25	258	840	4xM27	840	4xM33	863	4x1 1/4"
750	30"	1150	600	190	65	110	-	F25	296	900	4xM30	900	4xM33	914	4x1 1/4"
800	32"	1248	655	190	65	110	-	F25	330	950	4xM30	950	4xM36	978	4x1 1/2"
900	36"	1325	685	203	80	110	-	F25	505	1050	4xM30	1050	4xM36	1086	4x1 1/2"
1000	40"	1457	754	216	80	110	-	F25	661	1160	4xM33	1170	4xM39	1200	4x1 1/2"
1100	44"	1580	815	216	80	110	-	F25	840	1270	4xM33	1270	4xM39	1314	4x1 1/2"
1200	48"	1721	873	254	100	110	-	F25	1020	1380	4xM36	1390	4xM45	1422	4x1 1/2"
1300	52"	1910	1005	360	120	120	-	F30	1650	-	-	-	-	1537	4x1 3/4"
1400	56"	1990	1025	360	120	130	-	F30	1900	1590	4xM39	1590	4xM45	1651	4x1 3/4"
1600	64"	2320	1190	360	150	160	-	F35	2350	1820	4xM45	1820	4xM52	1879,6	4x1 7/8"

• Dimensions are nominal +/- 1 mm
• Subject to change without notice

Wafer

► Valve with accesories

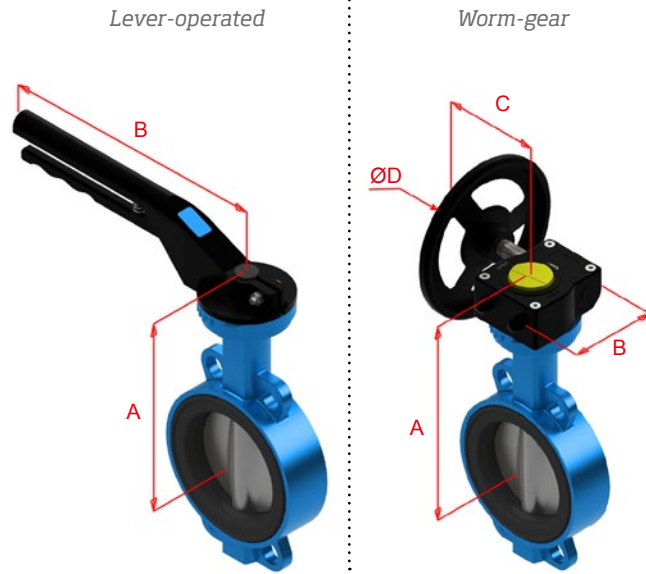

Diámetro nominal		Mando palanca			Reductor				
Nominal size		Lever-operated			Worm-gear				
(mm)	In	A	B	Peso Weight	A	B	C	ØD	Peso Weight
32	1 1/4"	170	205	2,5	198	128	116	140	3,5
40	1 1/2"	170	205	2,5	198	128	116	140	3,5
50	2"	186	205	4	214	128	116	140	5
65	2 1/2"	191	205	5	219	128	116	140	6
80	3"	199	205	5,5	227	128	116	140	6,5
100	4"	217	205	7	245	128	116	140	8
125	5"	235	330	9,5	264	128	120	200	10
150	6"	145	330	10,5	273	128	120	200	11
200	8"	285	330	16,5	313	128	120	200	17
250	10"	331	600	25	322	175	223	300	25,5
300	12"	363	600	33	354	175	223	300	34
350	14"	-	-	-	398	224	322	400	48,5
400	16"	-	-	-	438	224	322	400	61,5
450	18"	-	-	-	486	226	381	600	106
500	20"	-	-	-	542	258	402	600	144
600	24"	-	-	-	630	322,5	447	700	216
700	28"	-	-	-	699	390	447	500	307
750	30"	-	-	-	723	390	447	500	345
800	32"	-	-	-	779	390	447	700	379
900	36"	-	-	-	824	469	500	600	580
1000	40"	-	-	-	894	469	500	600	736
1100	44"	-	-	-	954	469	500	600	927
1200	48"	-	-	-	1012	574	556	800	1107
1300	52"	-	-	-	1237	574	589	700	1882
1400	56"	-	-	-	1257	713	589	700	2132
1600	64"	-	-	-	1422	713	589	700	2582

Lug

► Valve dimensions

FIG. 1 DN32-400

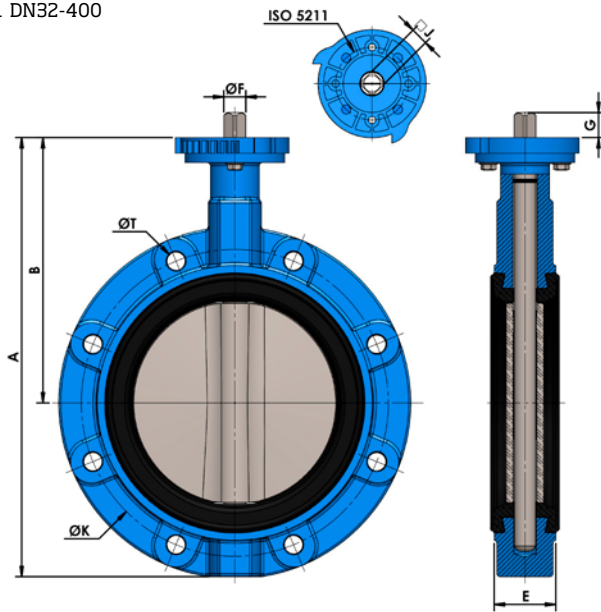
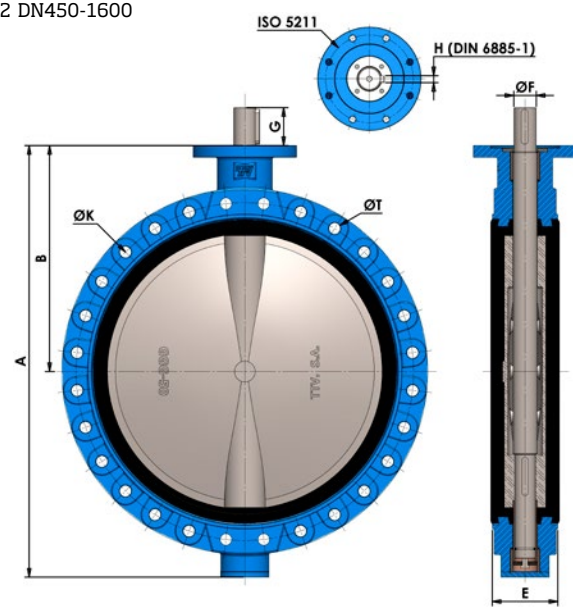

FIG. 2 DN450-1600



Valves dimensions										PN10	PN16	ANSI150			
DN		A	B	E	F	G	J	ISO 5211	Weight (Kg)	K	Holes N°xT	K	Holes N°xT	K	Holes N°xT
mm	In														

FIG. 1 DN32-400

32	1 1/4"	205	140	33	9,8	14	8	4x9	3	100	4xM16	100	4xM16	88,9	4x1/2"
40	1 1/2"	205	140	33	9,8	14	8	4x9	3	110	4xM16	110	4xM16	98,5	4x1/2"
50	2"	226	156	43	9,8	14	8	4x9	3,5	125	4xM16	125	4xM16	120,6	4x5/8"
65	2 1/2"	246	161	46	12	16	9	4x9	4,5	145	4xM16	145	4xM16	139,7	4x5/8"
80	3"	259	169	46	14	16	11	4x9	6,5	160	8xM16	160	8xM16	152,4	4x5/8"
100	4"	295	187	52	14	20	11	4x9	8	180	8xM16	180	8xM16	190,5	8x5/8"
125	5"	325	206	56	18	20	14	4x9	11	210	8xM16	210	8xM16	215,9	8x3/4"
150	6"	352	215	56	18	20	14	4x9	12	240	8xM20	240	8xM20	241,3	8x3/4"
200	8"	422	255	60	22	24	17	4x9	18,5	295	8xM20	295	12xM20	298,5	8x3/4"
250	10"	460	248	68	25	24	19	4x11	28,5	350	12xM20	355	12xM24	362	12x7/8"
300	12"	523	280	78	28	24	22	4x11	42	400	12xM20	410	12xM24	431,8	12x7/8"
350	14"	570	300	78	28	29	22	4x18	53	460	16xM20	470	16xM24	476,3	12x1"
400	16"	644	340	102	35	29	27	4x18	77	515	16xM24	525	16xM27	539,8	16x1"

FIG. 2 DN450-1600

450	18"	738	390	114	50	80	-	4x18	110	565	20xM24	585	20xM27	577,9	16x1 1/8"
500	20"	825	440	127	50	80	-	4x18	135	620	20xM24	650	20xM30	635	20x1 1/8"
600	24"	965	507	154	60	90	-	4x22	210	725	20xM27	770	20xM33	749,3	20x1 1/4"
700	28"	1100	575	165	60	90	-	8x18	290	840	24xM27	840	24xM33	863	28x1 1/4"
750	30"	1150	600	190	65	110	-	8x18	360	900	24xM30	900	24xM33	914	28x1 1/4"
800	32"	1248	655	190	65	110	-	8x18	450	950	24xM30	950	24xM36	978	28x1 1/2"
900	36"	1325	685	203	80	110	-	8x18	550	1050	28xM30	1050	28xM36	1086	32x1 1/2"
1000	40"	1454	754	216	80	110	-	8x18	760	1160	28xM33	1170	28xM39	1200	36x1 1/2"
1100	44"	1580	815	216	80	110	-	8x18	1020	1270	32xM33	1270	32xM39	1314	40x1 1/2"
1200	48"	1720	873	254	100	110	-	8x18	1460	1380	32xM36	1390	32xM45	1422	44x1 1/2"
1300	52"	1910	1005	360	120	130	-	8x22	2330	-	-	-	-	1537	44x1 3/4"
1400	56"	1990	1025	360	120	130	-	8x22	2450	1590	36xM39	1590	36xM45	1651	48x1 3/4"
1600	64"	2320	1190	360	150	160	-	8x32	2940	1820	40xM45	1820	40xM52	1879,6	52x1 7/8"

• Dimensions are nominal +/- 1 mm
• Subject to change without notice

Lug

► Valve with accesories

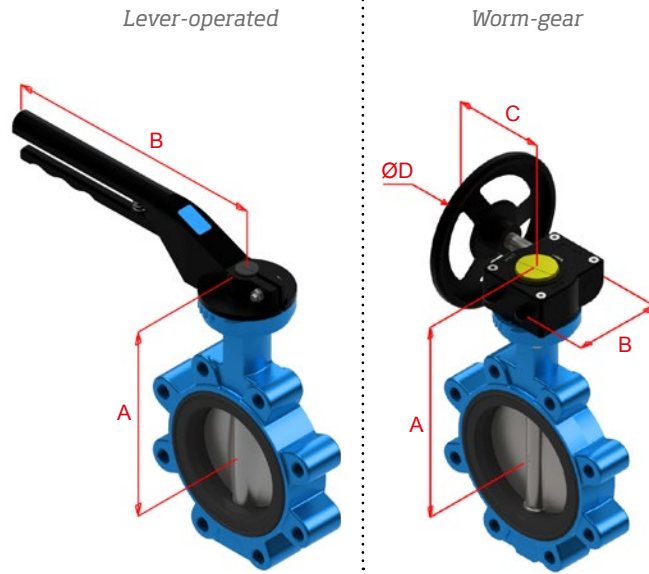

Diámetro nominal		Mando palanca			Reductor				
Nominal size		Lever-operated			Worm-gear				
(mm)	In	A	B	Peso Weight	A	B	C	ØD	Peso Weight
32	1 1/4"	170	205	3,5	198	128	116	140	4,5
40	1 1/2"	170	205	3,5	198	128	116	140	4,5
50	2"	186	205	4	214	128	116	140	5
65	2 1/2"	191	205	5	219	128	116	140	6
80	3"	199	205	7	227	128	116	140	8
100	4"	217	205	8,5	245	128	116	140	9,5
125	5"	236	330	12	264	128	120	200	13
150	6"	245	330	13	273	128	120	200	14
200	8"	285	330	19,5	313	128	120	200	20,5
250	10"	331	600	31	322	175	223	300	32,5
300	12"	363	600	44,5	354	175	223	300	46
350	14"	-	-	-	398	224	322	400	62,5
400	16"	-	-	-	438	224	322	400	86,5
450	18"	-	-	-	483	226	381	600	129
500	20"	-	-	-	542	258	402	600	162
600	24"	-	-	-	630	322,5	447	700	248,5
700	28"	-	-	-	699	403	447	500	339
750	30"	-	-	-	723	390	447	500	409
800	32"	-	-	-	779	390	447	700	499
900	36"	-	-	-	824	469	500	600	625
1000	40"	-	-	-	893	469	500	600	835
1100	44"	-	-	-	954	469	500	600	1107
1200	48"	-	-	-	1012	370	556	800	1547
1300	52"	-	-	-	1237	510	589	700	2562
1400	56"	-	-	-	1257	510	589	700	2682
1600	64"	-	-	-	1422	510	589	700	3172

Flanged

► Valve dimensions

FIG. 1 DN32-400

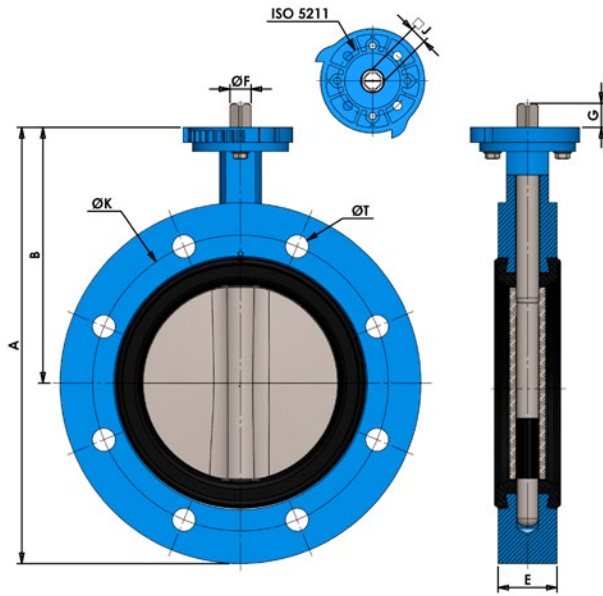
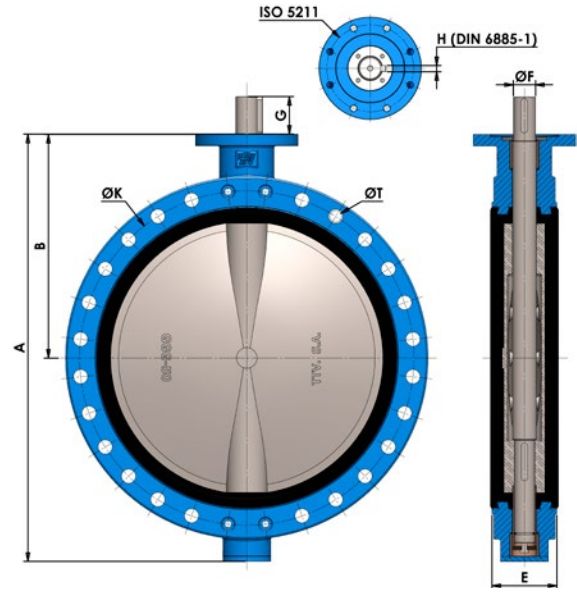

FIG. 2 DN450-1600



Valves dimensions										PN10		PN16			ANSI150			
DN		A	B	E	F	G	J	ISO 5211	Weight (Kg)	K	Holes		K	Holes		K	Holes	
mm	In										N°xT	N°xT1		N°xT	N°xT1		N°xT	N°xT1

FIG. 1 DN32-400

50	2"	239	156	43	9,8	14	8	F05/07	6	125	4x19	-	125	4x19	-	120,6	4x19	-
65	2 1/2"	254	161	46	12	16	9	F05/07	7.5	145	4x19	-	145	4x19	-	139,7	4x19	-
80	3"	269	169	46	14	16	11	F05/07	9	160	8x19	-	160	8x19	-	152,4	4x19	-
100	4"	306	187	52	14	20	11	F05/07	12	180	8x19	-	180	8x19	-	190,5	8x19	-
125	5"	337	207	56	18	20	14	F07	16	210	8x19	-	210	8x19	-	216	8x23	-
150	6"	361	215	56	18	20	14	F07	14	240	8x23	-	240	8x23	-	241,3	8x23	-
200	8"	435	255	60	22	24	17	F07	22	295	8x23	-	295	12x23	-	298,5	8x23	-
250	10"	458	248	68	25	24	19	F10	34	350	8x23	4xM20	355	8x27	4xM24	362	8x26	4x7/8"
300	12"	521	280	78	28	24	22	F10	48	400	8x23	4xM20	410	8x27	4xM24	431,8	8x26	4x7/8"
350	14"	565	300	78	28	29	22	F14	58	460	12x23	4xM20	470	12x27	4xM24	476,3	8x29	4x1"
400	16"	645	340	102	35	29	27	F14	81	515	12x27	4xM24	525	12x30	4xM27	539,8	12x29	4x1"

FIG. 2 DN450-1600

450	18"	736	390	114	50	80	-	F14	118	565	16x27	4xM24	585	16x30	4xM27	577,9	12x32	4x1 1/8"
500	20"	825	440	127	50	80	-	F14	144	620	16x27	4xM24	650	16x33	4xM30	635	16x32	4x1 1/8"
600	24"	965	507	154	60	90	-	F16	220	725	16x30	4xM27	770	16x36	4xM33	749,3	16x36	4x1 1/4"
700	28"	1100	575	165	60	90	-	F25	300	840	20x30	4xM27	840	20x36	4xM33	863	24x36	4x1 1/4"
750	30"	1150	600	190	65	110	-	F25	370	900	20x33	4xM30	900	20x36	4xM33	914	24x36	4x1 1/4"
800	32"	1248	655	190	65	110	-	F25	415	950	20x33	4xM30	950	20x39	4xM36	978	24x41	4x1 1/2"
900	36"	1325	685	203	80	110	-	F25	565	1050	24x33	4xM30	1050	24x39	4xM36	1086	28x41	4x1 1/2"
1000	40"	1457	754	216	80	110	-	F25	775	1160	24x36	4xM33	1170	24x42	4xM39	1200	32x41	4x1 1/2"
1100	44"	1580	815	216	80	110	-	F25	990	1270	28x36	4xM33	1270	28x42	4xM39	1314	36x41	4x1 1/2"
1200	48"	1721	873	254	100	110	-	F25	1350	1380	28x39	4xM36	1390	28x48	4xM45	1422	40x41	4x1 1/2"
1300	52"	1910	1005	360	120	130	-	F30	2100	-	-	-	-	-	-	1537	40x48	4x1 3/4"
1400	56"	1990	1025	360	120	130	-	F30	2450	1590	32x42	4xM39	1590	32x48	4xM45	1651	44x48	4x1 3/4"
1600	64"	2320	1190	360	150	160	-	F35	2710	1820	36x48	4xM45	1820	36x56	4xM52	1879,6	44x51	4x1 7/8"
1800	72"	2525	1310	360	150	170	-	F35	3100	2020	36x48	8xM45	2020	36x56	8xM52	2096	52x51	8x1 7/8"
2000	80"	2680	1360	360	150	170	-	F35	3650	2230	40x48	8xM45	2230	40x62	8xM56	2311	52x54	8x2"

• Dimensions are nominal +/- 1 mm
• Subject to change without notice

Flanged

► Valve with accesories

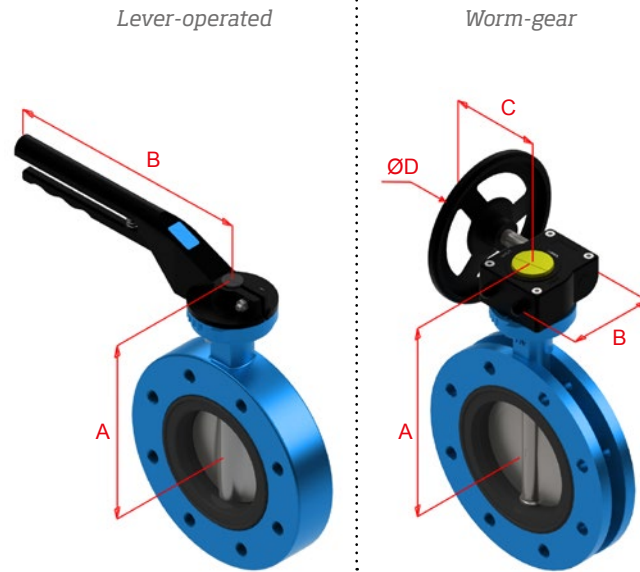

Diámetro nominal		Mando palanca			Reductor				
Nominal size		Lever-operated			Worm-gear				
(mm)	In	A	B	Peso Weight	A	B	C	ØD	Peso Weight
50	2"	186	205	7	214	128	116	140	7
65	2 1/2"	191	205	7,5	219	128	116	140	7,5
80	3"	199	205	9	227	128	116	140	9
100	4"	217	205	13,5	245	128	116	140	13,5
125	5"	237	205	17,5	264	128	120	200	18
150	6"	245	205	15,5	273	128	120	200	16
200	8"	285	330	23,5	313	128	120	200	24
250	10"	331	330	41,5	322	175	223	300	38
300	12"	363	330	55,5	354	175	223	300	52
350	14"	387	330	65,5	398	224	322	400	67,5
400	16"	423	330	88,5	438	224	322	400	90,5
450	18"	-	-	-	482	226	381	600	137
500	20"	-	-	-	542	258	402	600	171
600	24"	-	-	-	630	322,5	447	700	258,5
700	28"	-	-	-	699	403	447	500	349
750	30"	-	-	-	723	390	447	500	419
800	32"	-	-	-	779	390	447	700	464
900	36"	-	-	-	824	469	500	600	640
1000	40"	-	-	-	893	469	500	600	850
1100	44"	-	-	-	954	469	500	600	1077
1200	48"	-	-	-	1012	370	556	800	1437
1300	52"	-	-	-	1237	510	589	700	2332
1400	56"	-	-	-	1257	510	589	700	2682
1600	64"	-	-	-	1422	510	589	700	2942
1400	56"	-	-	-	1257	713	589	700	2132
1600	64"	-	-	-	1422	713	589	700	2582



CR-TEC reserves the right to change or remove products or services from its range at any time and without prior notification or obligation. CR-TEC does not assume any liability for consequences resulting from the use of this document. There is no guarantee that the information provided here is complete, accurate or up to date.

CR-TEC Engineering Inc.

CR-TEC Engineering Inc.

15 Orchard Park Road, Unit 18
Madison, CT 06443
Telephone 203-318-9500 | Fax 203-245-2575
info@crtec.com | www.crtec.com