



CR-TEC Engineering

Automated Valve Solutions

**CRV3X Double Offset
High Performance Butterfly Valves**



► Geometric design of double offset butterfly valves

Due to the **double offset movement**, the rotation of the disc is eccentric over the seat.

The rotational circular movement of the disc turns into an elliptical movement. So, the disc achieves just a few degrees contact with the seat before the valve is fully closed.

Double offset design characteristics:

- **Longer lifetime**, minimum friction between disc and seat.
- **Tight sealing in closed position** regardless the pressure due to the strain of disc over the seat.
- Self sealing mechanism that assures **tight sealing and low torque values**.
- The offset shaft design allows an easy replacement of seat without dismantling the shaft or other inner components assures quick on site maintenance.
- Colossus double offset butterfly valves provide the **high performance** of ball and gate valves with the low cost and light weight characteristics of butterfly valves.

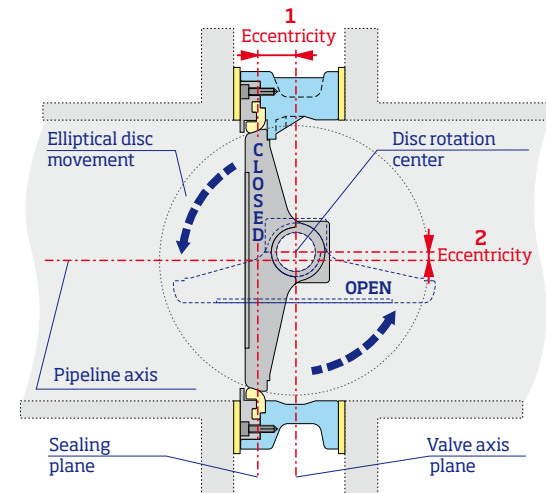

► General Characteristics



Colossus Metal - Metal

- **Available design for wafer, lug and flanged type.**
- **Under request, special design available.**
- **Same design for two types of seat:**
Soft seat: R-PTFE (-50°C / +220°C)
Hard seat: F-316L (-100°C / +500°C)
- **Easy seat replacement in all cases.**
- **Body:**
Cast Steel A216WCB
Stainless Steel CF8M
- **Disc:**
Stainless Steel CF8M
- **Shaft:**
Stainless Steel F-316
- **Inspection and testing:**
ISO 5208 / API 598
- **Working pressure:**
Up to Class 300
- **Flanges:**
ISO 5752 series 20
BS 5155 series 4
DIN - PN 10 / 16 / 25
ANSI 150Lbs / 300 Lbs
- **Actuator flange assembly:**
ISO 5211
- **Design:**
API 609
ASME B16.34
MSS SP-67
EN 593
Nace MR 0175



Wafer metal-metal

► Soft seat: R-PTFE

Temperature: CF-8M Body (-50°C to + 220°C) | WCB Body (-29°C to +200°C)
Class VI tightness, 0% leakage, PN 10/16/25/40.

The retainer, 5, holds and isolates the R-PTFE polymer, 4, from direct contact with the pipe flange, keeping the seat in static position, without deformations. Packings, which are used in the top of the valve shaft, are chevron type 60°, and made of PTFE material; as a special request they can be made of graphite. The R-PTFE seat (PTFE+ 25% Glass fiber) can be used with all kinds of chemicals, except alkali metals in the elemental state, chlorine trifluoride, elemental fluorine at high temperatures and pressures or its by-products, concentrated nitric acid and sulfuric acid to 65% or higher.

Fire safe certificate for soft seat.

Generally, the use of R-PTFE seat is **recommended in very aggressive chemical circuits** and in circuits where different kinds of products are used, such as:

- Vacuum Services
- Chemical
- Petroleum products
- Ethylene
- LPG / LNG
- Vegetable oils
- Derivatives of hydrocarbons
- Steam
- Air
- Drinking water
- Saturated water
- Seawater

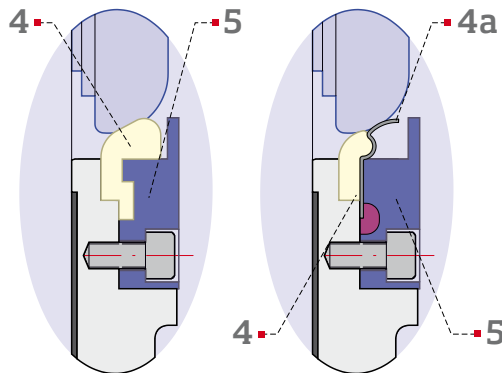

► Hard seat: Metal - Metal

Temperature: From -100°C to + 360°C.
Special design for 500°C.
Class V tightness, PN 10/16/25/40.

Metal seat, 4, can be rigid or flexible, depending on the service.
The spherical surface of the disc in these seats is coated with **hard chromium** or it can be **stellite** if service demands it.

Packings are made of graphite and bushes are stainless steel coated with a PTFE alloy and graphite.

Metal - Metal seat complies with **BS 6755 part 2 or API 6FA/607 (Fire Safety)**.

It is usually used in services where the R-PTFE is not suitable due to temperature or any other exceptions.

Besides the applications mentioned for R-PTFE, metal-metal seat is also valid for:

- Saturated Steam
- Thermal insulation gases
- Bitumen / Asphalt
- Corrosive liquid
- Thermal Oil
- Cogeneration

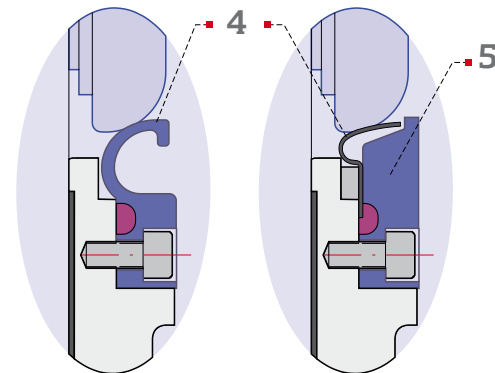

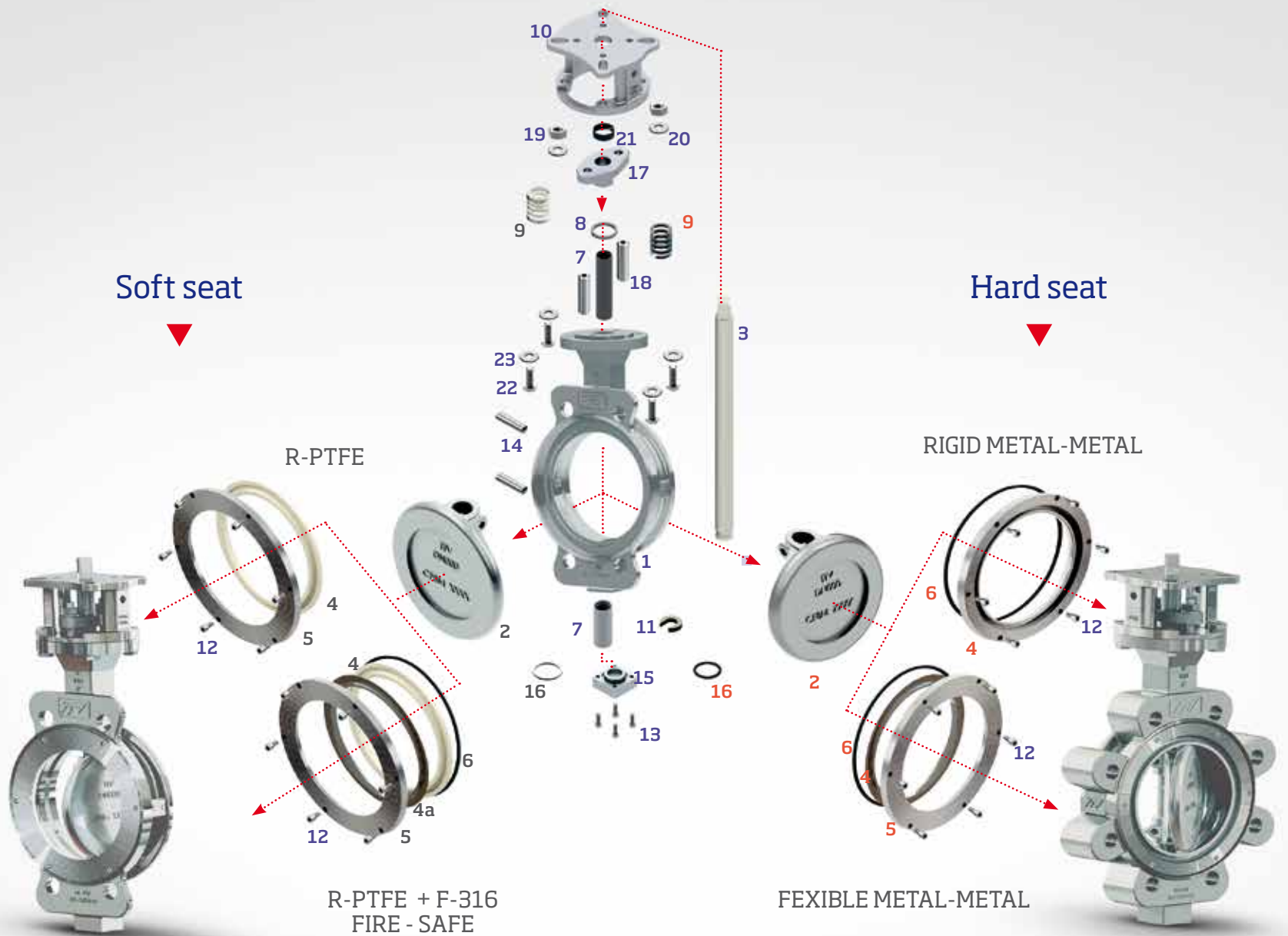

As shown in the drawing, **the two types of seat are mounted under a same construction type**, and both share the same components indicated in the "table general parts list". The complete set of materials of each model depends on the type of seat and is shown below the general parts list.

► General parts list

Item	Designation	Material
1	Body	CF8M or A216 WCB
3	Shaft	F-316
7	Bush	CF8M + PTFE + Gr
8	Packing Washer	F-316
10	Bracket	CF8M or A216 WCB
11	Shaft retainer ring	F-316
12	Screw	A4 (F-316)
13	Bottom cover screw	A4 (F-316)
14	Pin	A4 (F-316)
15	Bottom cover	CF8M or A216 WCB
17	Gland flange	CF8M
18	Gland bolt	A4 (F-316)
19	Nut	A4 (F-316)
20	Spring washer	A4 (F-316)
21	Bracket top bearing	CF-8M + PTFE + Gr
22	Screw	A4 (F-316)
23	Spring washer	A4 (F-316)



► Soft seat: R - PTFE

Item	Designation	Material
2	Disc	CF8M (grinding and polishing)
5	Retainer	F-316L
R - PTFE		
4	RPTFE seat	PTFE + 25% Glass Fiber
9	Packing	PTFE
16	Cap packing	PTFE
R - PTFE / FIRE SAFE		
4	RPTFE seat	PTFE+ 25% Glass Fiber
4a	Flexible seat	F-316L
6	Gasket	Graphite
9	Packing	Graphite
16	Cap packing	Graphite

► Hard seat: Metal - Metal

Item	Designation	Material
2	Disc	CF8M+ hard chrome (polished)
6	Gasket	Graphite
9	Packing	Graphite
16	Cap packing	Graphite
Metal - Metal. FLEXIBLE Type		
4	Seat (sheet)	F-316L
5	Retainer	F-316L
Metal - Metal. RIGID Type		
4	Seat (machined)	F-316L

Double offset
Butterfly Valves



Double offset high performance butterfly valves

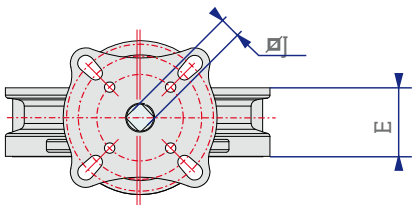
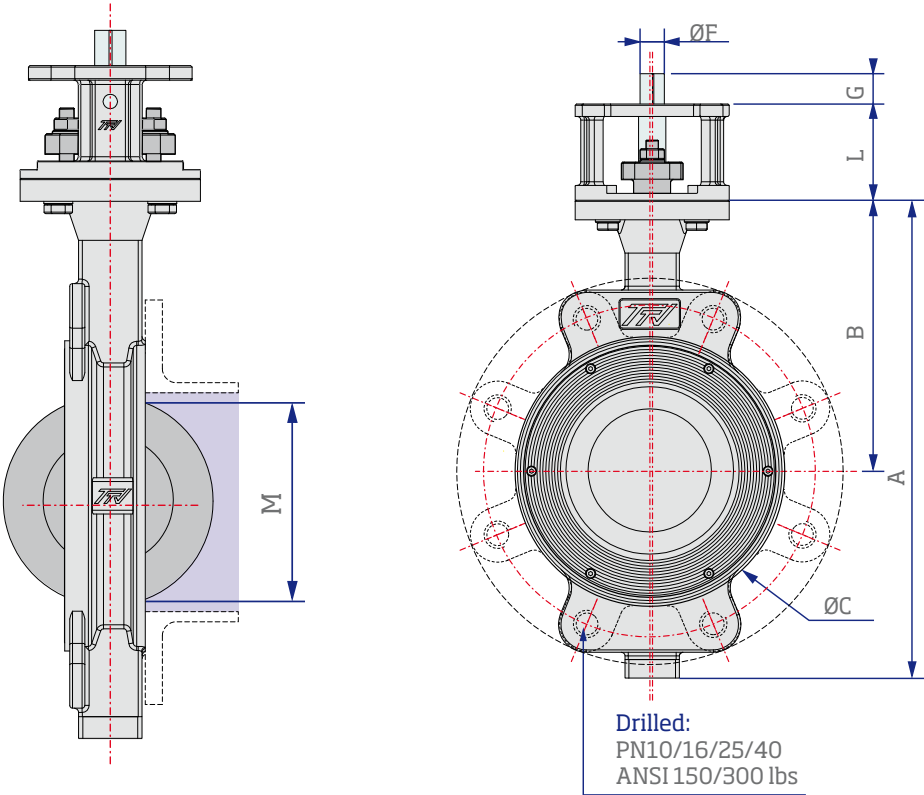

Flanged type



Wafer type



Lug type



Same dimensions for Flanged, Wafer and Lug

► Dimensions

DN		A	B	C	E	F	G	J	L	M	ISO5211	Weight (Kg)		
mm	inch											Wafer	Lug	Flanged
50	2"	218	128	102	43	12	14	9	70	32	F05-F07	4,6	6	6
65	2 1/2"	228	140	120	46,5	14	14	11	70	48	F05-F07	5,3	7	7
80	3"	259	148	138	47	17	15	14	70	70	F05-F07	6,4	9	9
100	4"	295	169	158	52	17	18	14	70	90	F05-F07	8	14	14
125	5"	350	200	190	56	21	22	17	80	116	F07-10-12	14	18	18
150	6"	388	220	215	56	21	24	17	80	141	F07-10-12	16	20	22
200	8"	450	250	265	63	26,5	32	22	90	187	F10-12-14	26	35	39
250	10"	548	305	325	71	26,5	39	27	106	226	F12-14-16	42	49	54
300	12"	621	342	370	78	33	50	27	106	274	F12-14-16	58	65	71
350	14"	632	326	416	78	36	37	27	106	329	F12-14-16	64	86	92
400	16"	712	370	476	102	48	47	36	120	377	F14-16	103	145	150
450	18"	765	395	534	114	48	47	36	120	423	F14-16	125	169	175
500	20"	829	430	588	127	60	56	46	120	471	F14-16-25	162	225	236
600	24"	945	490	692	154	60	56	46	150	572	F14-16-25	271	370	382

Subjet to change without notice. Drawings may not be the exact representation of manufacturing.

► Operating Torque

TORQUE - R-PTFE (Nm)				
mm	Inch	PN10	PN16	PN25
50	2"	12	17	25
65	2 1/2"	20	25	30
80	3"	31	40	55
100	4"	45	58	75
125	5"	52	65	105
150	6"	110	135	190
200	8"	150	226	314
250	10"	206	304	471
300	12"	314	471	726

TORQUE- Metal-Metal (Nm)				
mm	Inch	PN10	PN16	PN25
50	2"	18	19	33
65	2 1/2"	25	30	50
80	3"	40	50	75
100	4"	48	60	85
125	5"	85	110	320
150	6"	187	229	540
200	8"	300	452	750
250	10"	412	608	930
300	12"	785	1175	1750

Operating torque for larger diameters are available on request.

Operating torque data are valid for on/off service. Operating torque must be increased by 15% in case of regulating service.

► Flow coefficient CV

The valve Cv provides an index of capacity by which it is easy to estimate the required size of a restriction to control the flow of any piping system.

The usable range of measure of Colossus high performance butterfly valves is between 20 ° and 70 ° opening.

Liquid	$Cv = 1,72 \cdot Q \cdot \sqrt{\frac{G}{\Delta P}}$	
Gas	$Si \Delta P < \frac{P_1}{2}; Cv = \frac{Q}{272} \cdot \sqrt{\frac{G(273+T)}{\Delta P(P_1+P_2)}}$	$Si \Delta P \geq \frac{P_1}{2}; Cv = \frac{\sqrt{G(273+T)}}{236P_1}$
Steam	$Si \Delta P < \frac{P_1}{2}; Cv = \frac{WK}{13.5 \cdot \sqrt{\Delta P \cdot (P_1+P_2)}}$	$Si \Delta P \geq \frac{P_1}{2}; Cv = \frac{WK}{11.9 \cdot P_1}$

Q Flow (liquid m³/h, gas Nm³/h)
W Flow (steam kg/h)
P₁ Inlet pressure (Liquid Kgf/cm², gas and steam Kgf/cm²)
P₂ Outlet pressure (Liquid Kgf/cm², gas and steam Kgf/cm²)
ΔP Pressure drop P₁-P₂
G Specific gravity of the fluid
T Fluid temperature (°C)
K Correction coefficient of steam overheating, 1+0.0013xdeg°C of overheating

Note: When $P_2 < \frac{P_1}{2}$ use $\frac{P_1}{2}$ instead of ΔP



Flow characteristics

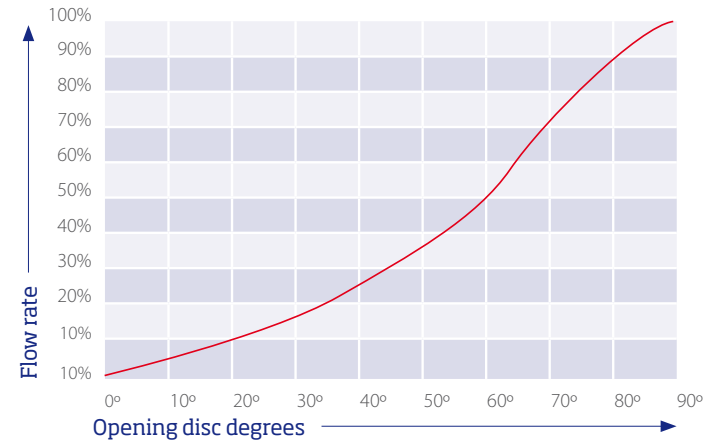

DN	20°	30°	40°	50°	60°	70°	80°	90°
50	2"	19	27	35	43	54	65	87
65	2 1/2"	17	26	34	43	62	82	121
80	3"	40	56	72	88	118	149	210
100	4"	40	88	137	186	243	300	413
125	5"	54	160	266	372	457	542	710
150	6"	71	227	363	499	634	770	1042
200	8"	179	432	686	939	1177	1426	1892
250	10"	320	674	1027	1380	1841	2301	3223
300	12"	358	914	1470	2027	2738	3449	4873
350	14"	487	811	1081	1216	1351	2750	5725
400	16"	634	931	1242	1396	2022	3245	7243
450	18"	596	1237	1650	1856	2875	4231	9863
500	20"	1150	1694	2528	3125	4285	7245	12234
600	24"	1951	3073	4957	6758	9875	12875	20436

► Installation

The valves can operate bidirectionally. If the pressure falls upon the face of the valve shaft, it is fully tight and if the pressure falls upon the opposite side, the breakaway torque is minimized and the seat wear is reduced. Depending on working conditions and the type of seat, a proper installation, will be selected in each case.

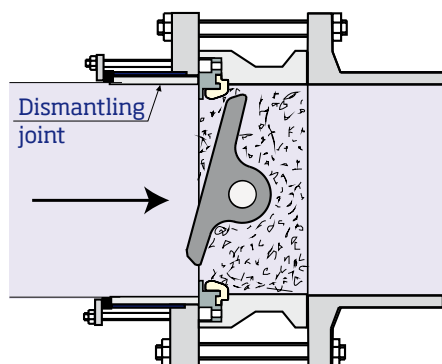

► Cavitation

Cavitation happens when a fluid passes through an area at a high speed producing a decompression of the fluid; it is usually caused by a local pressure drop below the steam pressure of the fluid.

This can cause a fast wear of valves and pipes, as well as noise and vibration problems.

To avoid cavitation it can be used the following formulas:

$$\xi = 1,57 \cdot 10^{-3} \cdot \frac{DN^4}{Kv^2}$$

$$z_y = 0.1 \cdot \log \xi + 0.14$$

$$X_f = \frac{\Delta P}{P_1 - P_v}$$

$$X_f < z_y$$

ξ Valve restriction factor
 X_f Pressure ratio
 P_1 Inlet pressure
DN Diameter

Z_y Cavitation value
 ΔP Pressure drop $P_1 - P_2$
 P_v Steam pressure of the liquid
 K_v Coefficient flow Kv



► Pressure | Temperature

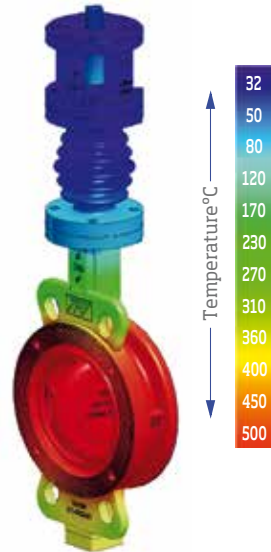

Research and simulation of material **mechanical properties evolution** subjected to high or very low temperatures.

The charts show the **range of temperature** and pressure depending on disc and seat materials.

Max Pressure - Working: 25 bar (363 psi)
 Max Pressure - Peak: 30 bar (435 psi)
 Max Pressure - Body: 75 bar (1088 psi)

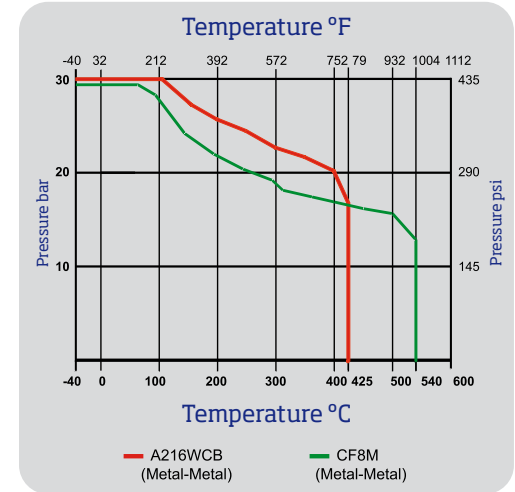
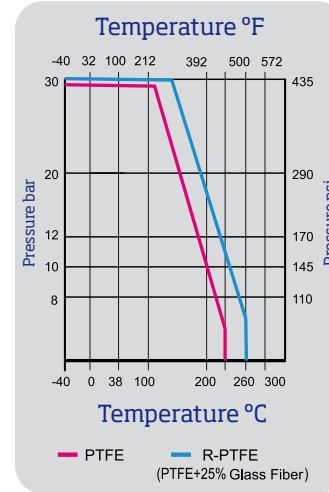

► Study of materials resistance under pressure

Performance and stress analysis according to ISO-5208 / API598 API598.

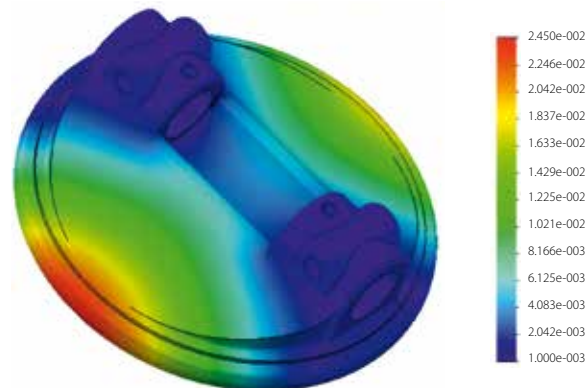

► Flow simulation

3D flow simulation to develop an **aerodynamic disc** with less noise and turbulence in the Colossus valve.

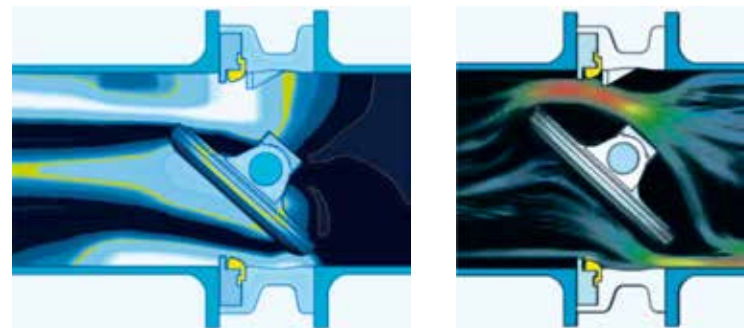

The information in this catalog is informative and has no contractual bearing.

Wafer PTFE





CR-TEC reserves the right to change or remove products or services from its range at any time and without prior notification or obligation. CR-TEC does not assume any liability for consequences resulting from the use of this document. There is no guarantee that the information provided here is complete, accurate or up to date.

CR-TEC Engineering
Automated Valve Solutions

CR-TEC Engineering Inc.

15 Orchard Park Road, Unit 18

Madison, CT 06443

Telephone 203-318-9500 | Fax 203-245-2575

info@crtec.com | www.crtec.com